



Betriebsanleitung

D

Operating Manual

EN

Mode d'emploi

F

Istruzioni per l'uso

IT

Instrucciones de servicio

ES

TR

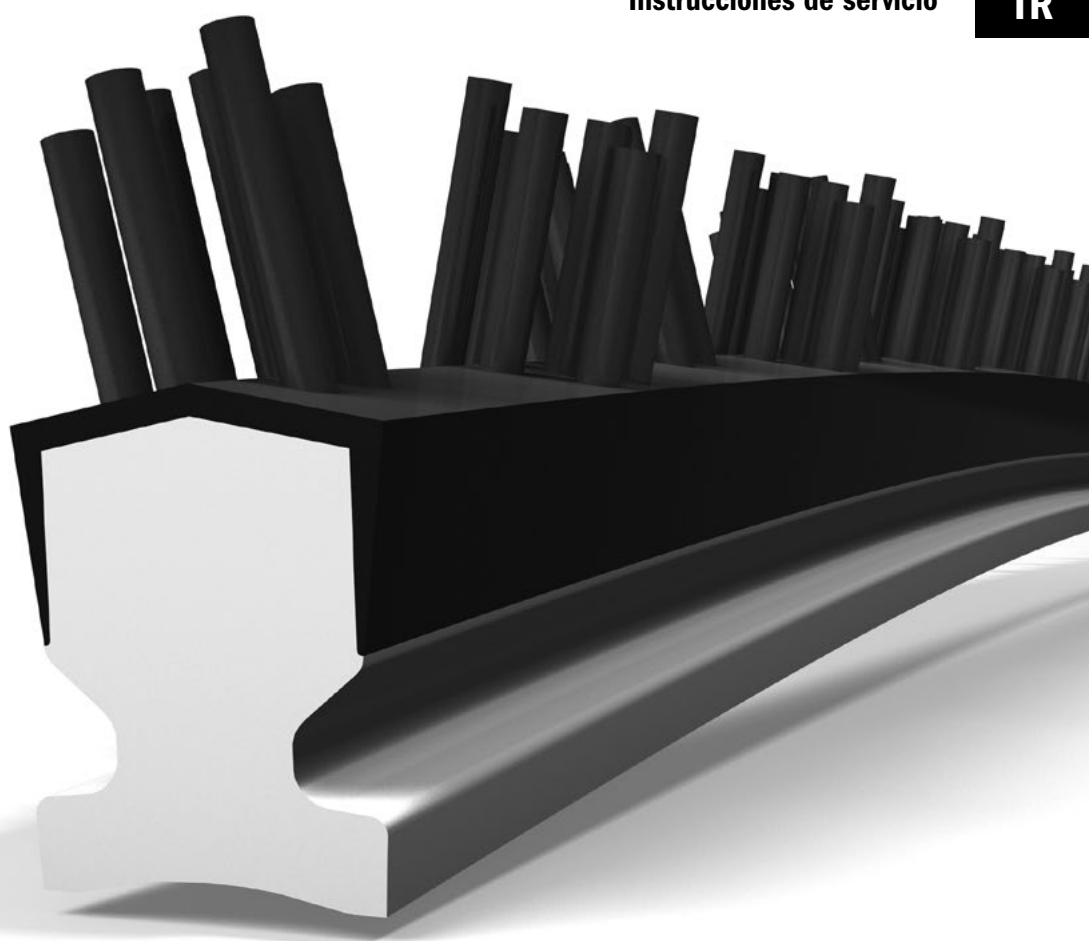

ProfilGate® i45 aqua
ProfilGate® sti45 aqua
ProfilGate® b55
ProfilGate® b55 go
ProfilGate® i55
ProfilGate® i55 go
ProfilGate® st55
ProfilGate® st55 go
ProfilGate® sti55
ProfilGate® sti55 go
ProfilGate® i55 aqua
ProfilGate® sti55 aqua
ProfilGate® xs55
ProfilGate® xs55 go
ProfilGate® b65
ProfilGate® b65 go
ProfilGate® st65
ProfilGate® st65 go
ProfilGate® xs65
ProfilGate® xs65 go



ProfilGate® b55 1x1 005-6750B | **1,5x1** 005-6110B

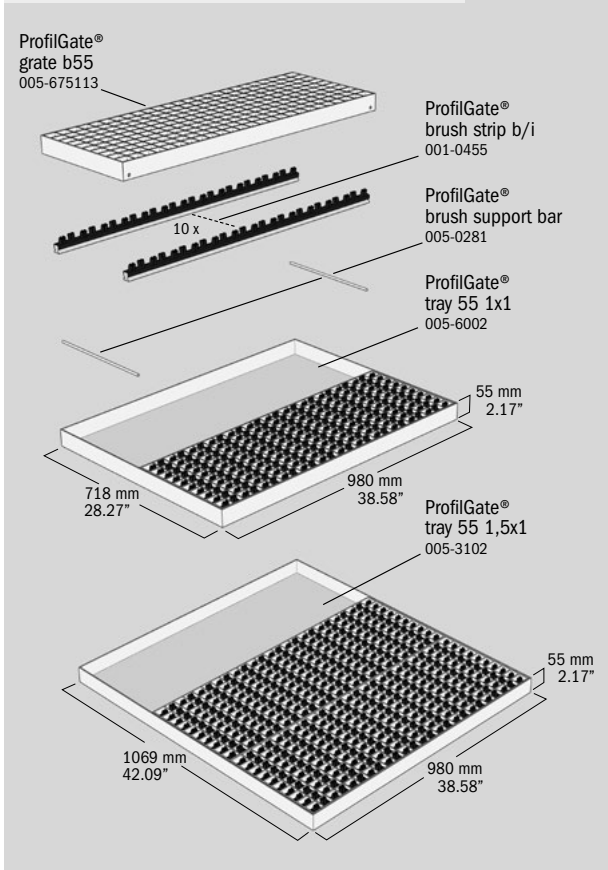

ProfilGate® b55 go 1x1 005-6750GO | **1,5x1** 005-6110GO

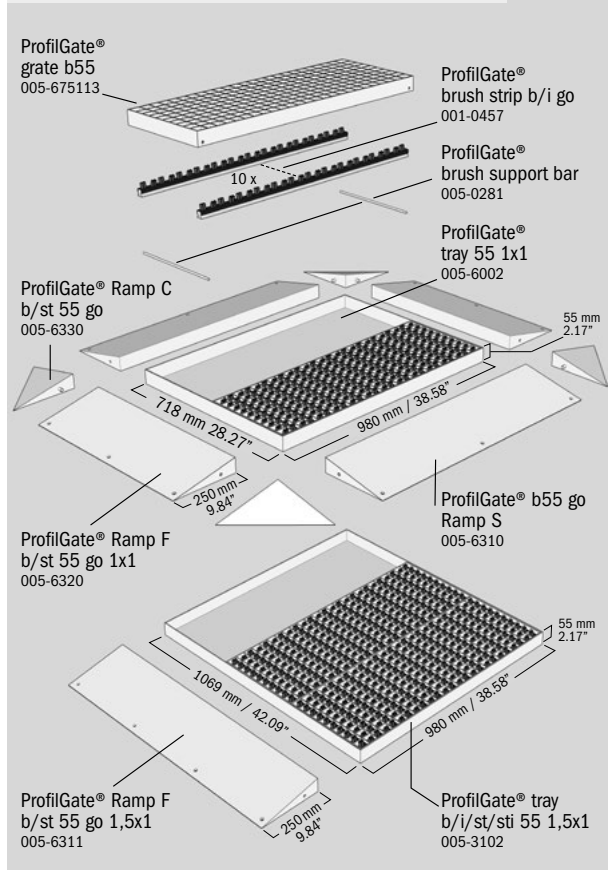

ProfilGate® b65 1x1 005-0750B | **1,5x1** 005-0110B

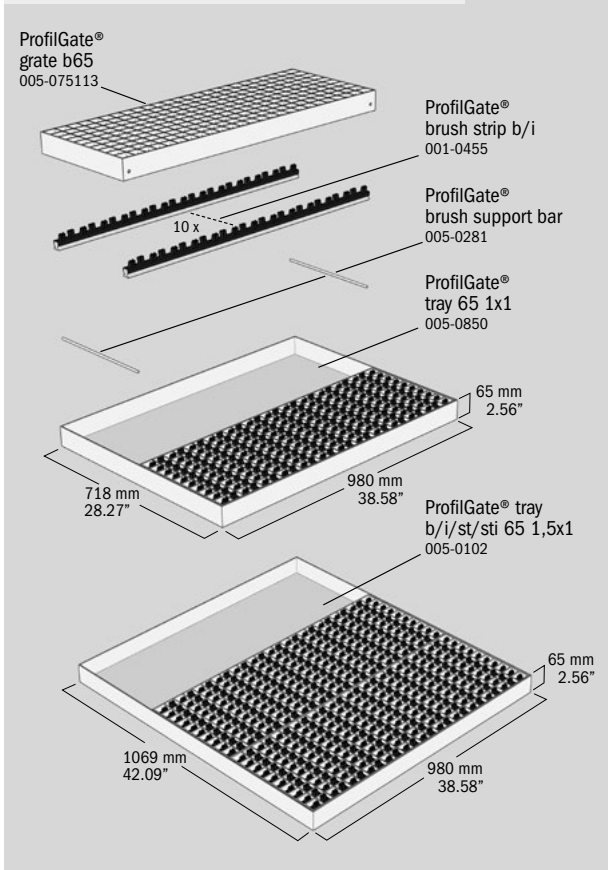

ProfilGate® b65 go 1x1 005-0750GO | **1,5x1** 005-0110GO

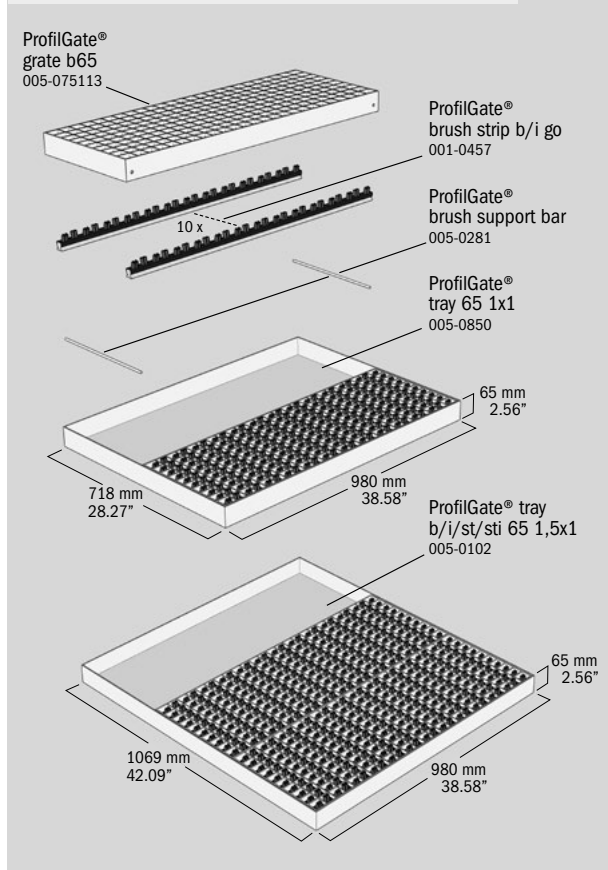

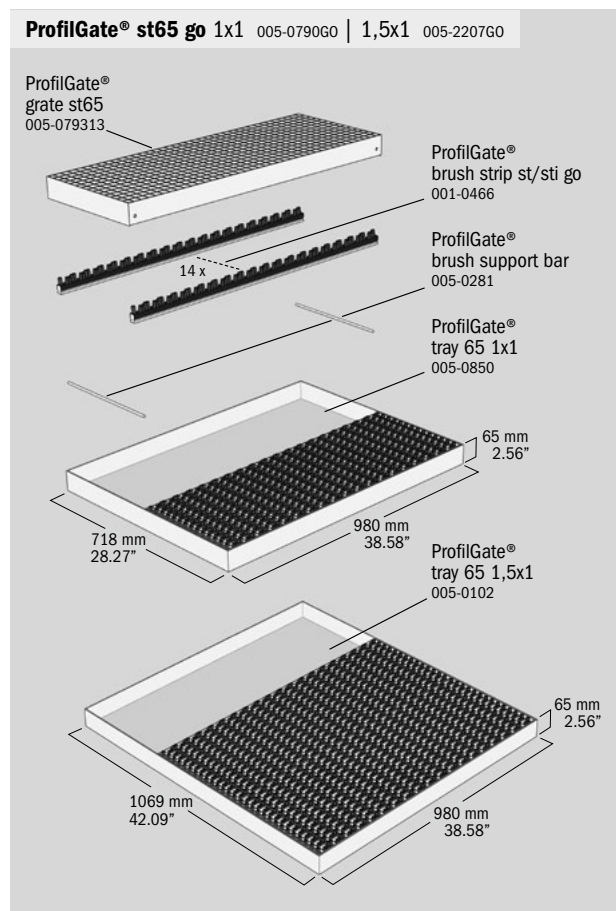
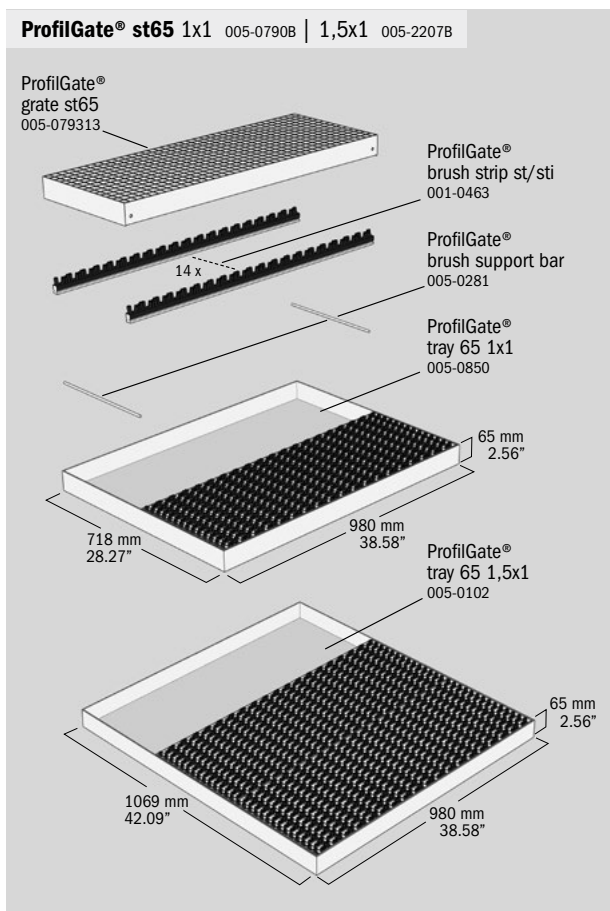
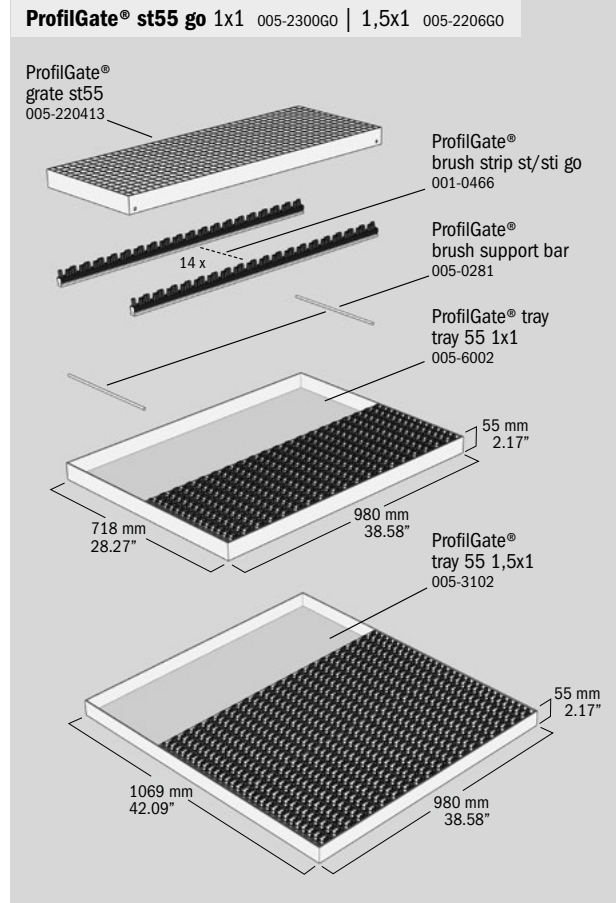
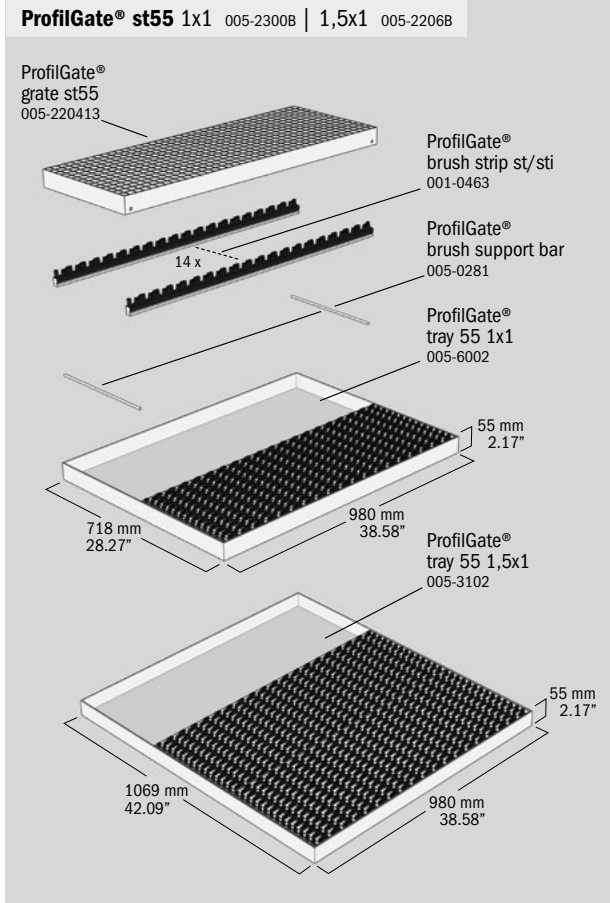

ProfilGate® i55 1x1 005-3000B | **1,5x1** 005-3100B

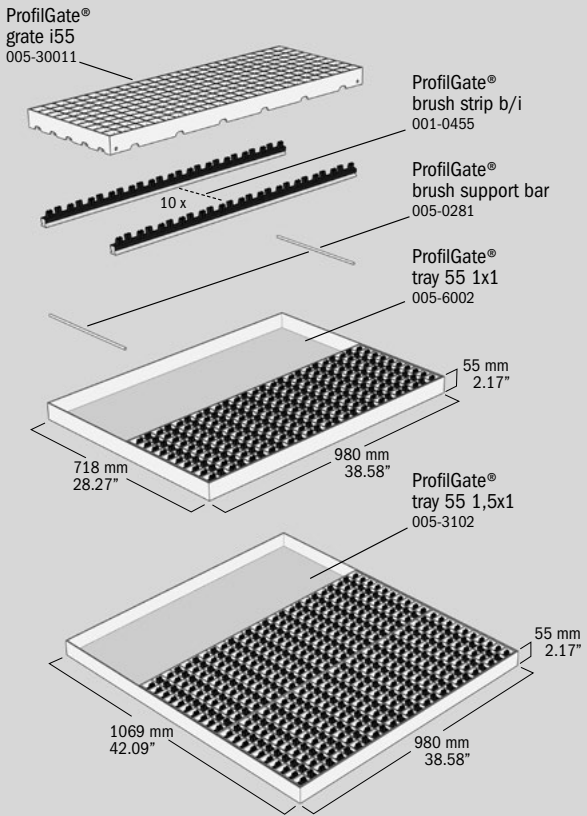

ProfilGate® i55 go 1x1 005-3000G0 | **1,5x1** 005-3100G0

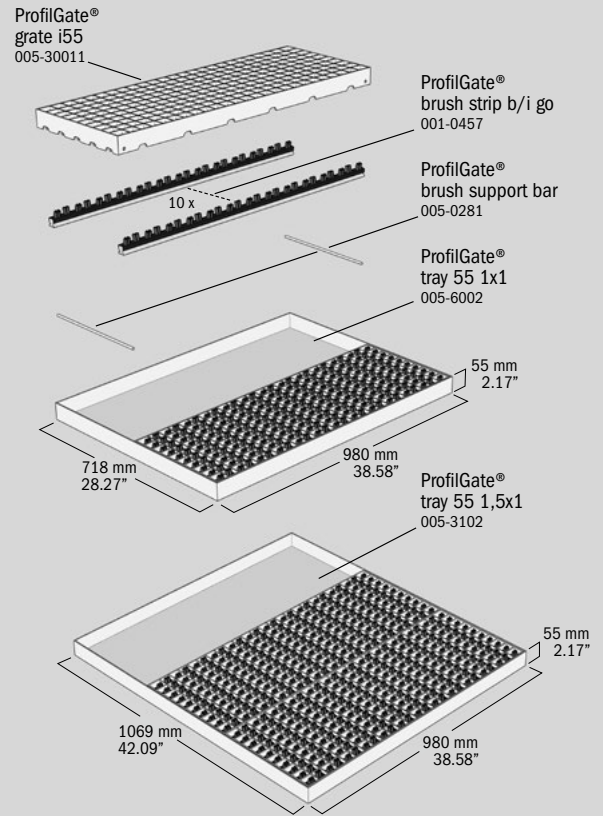

ProfilGate® sti55 1x1 005-2350B | **1,5x1** 005-2360B

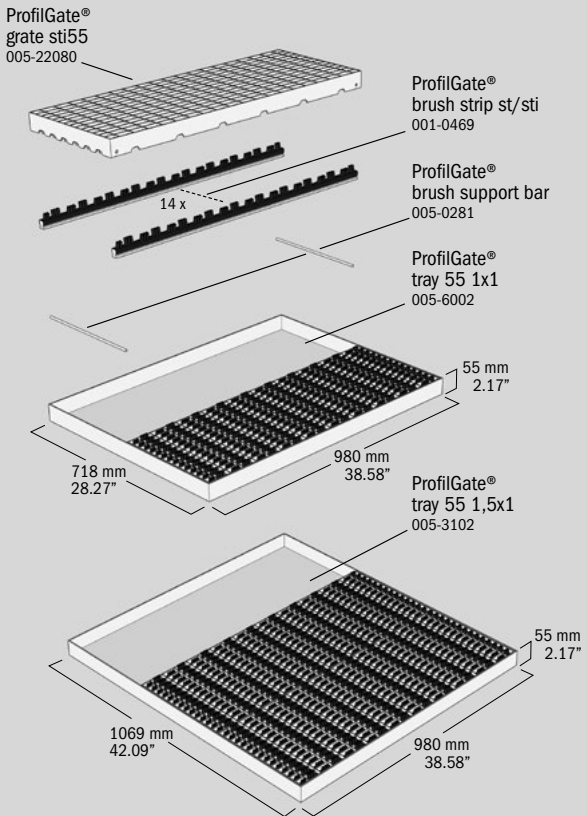

ProfilGate® sti55 go 1x1 005-2350G0 | **1,5x1** 005-2360G0

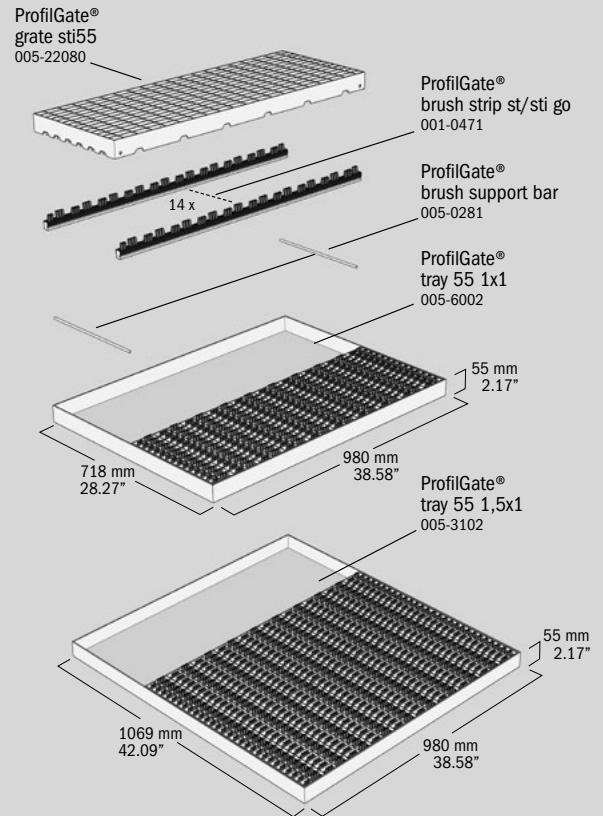

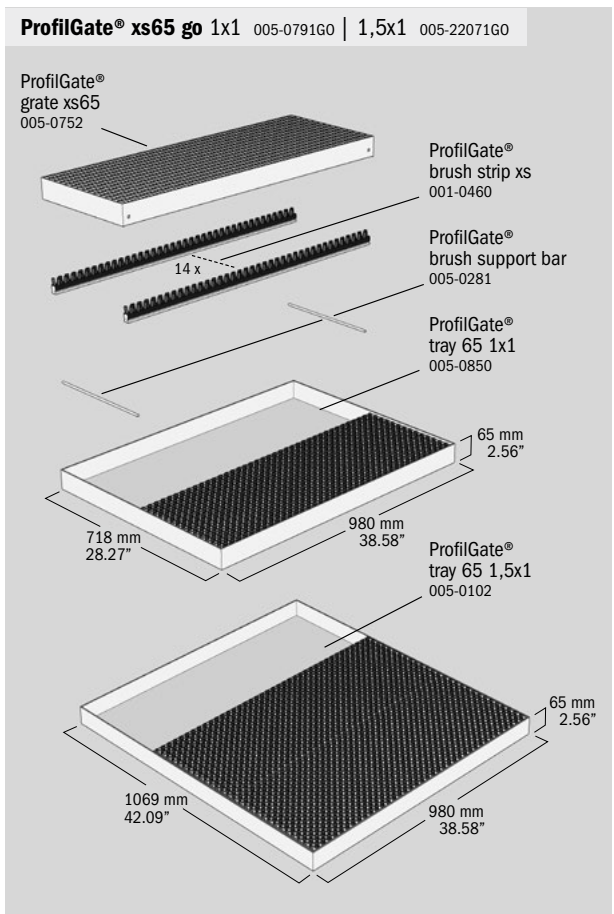
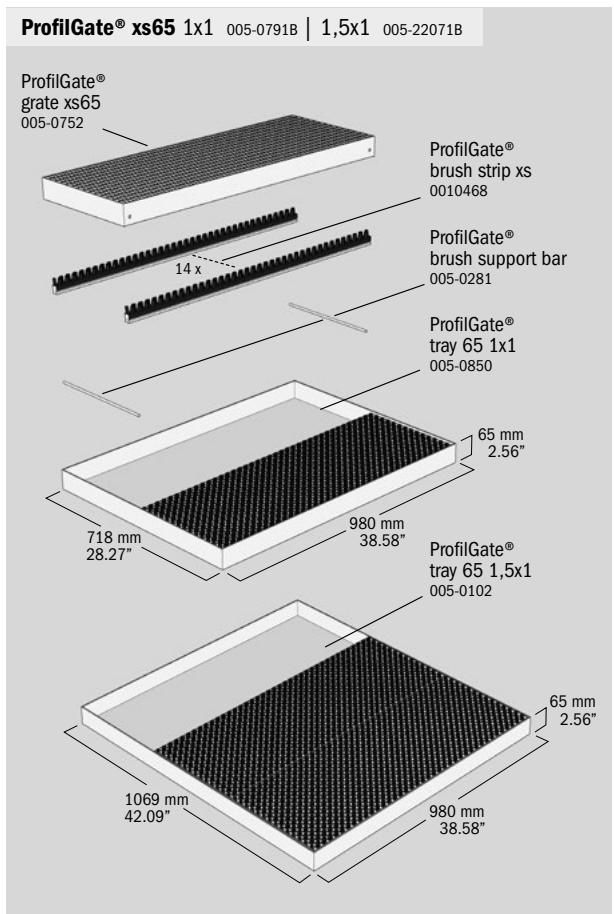
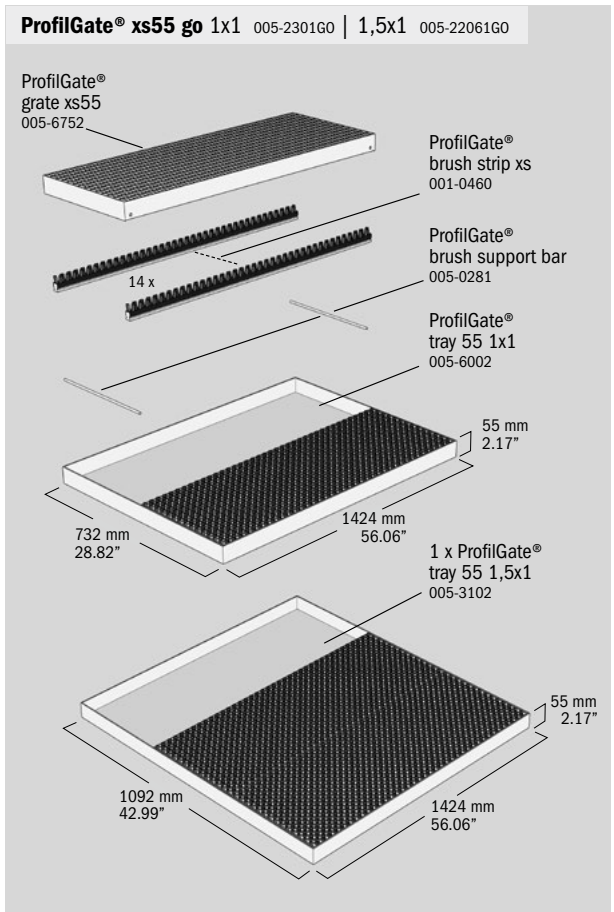
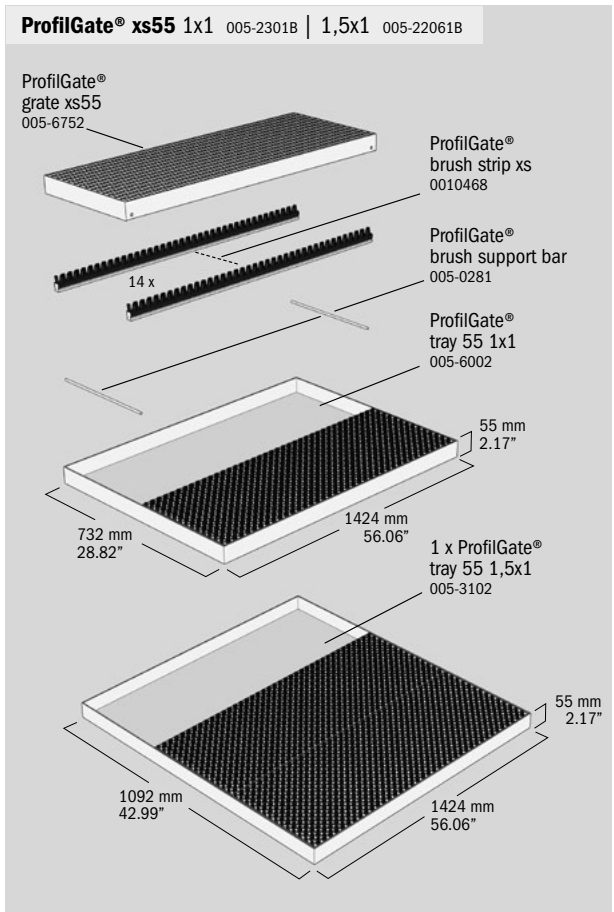

ProfilGate® i45 aqua with Drain Type A

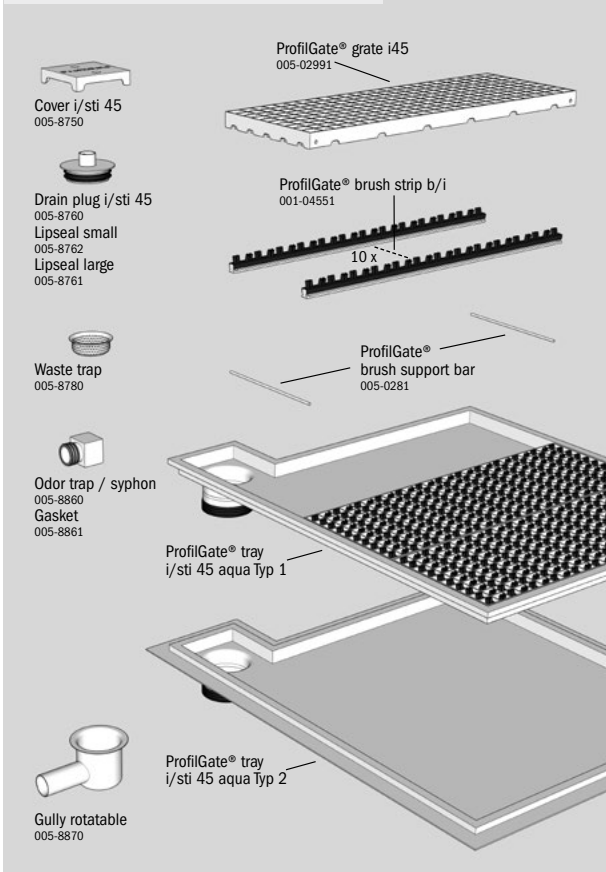

ProfilGate® i45 aqua with Drain Type B

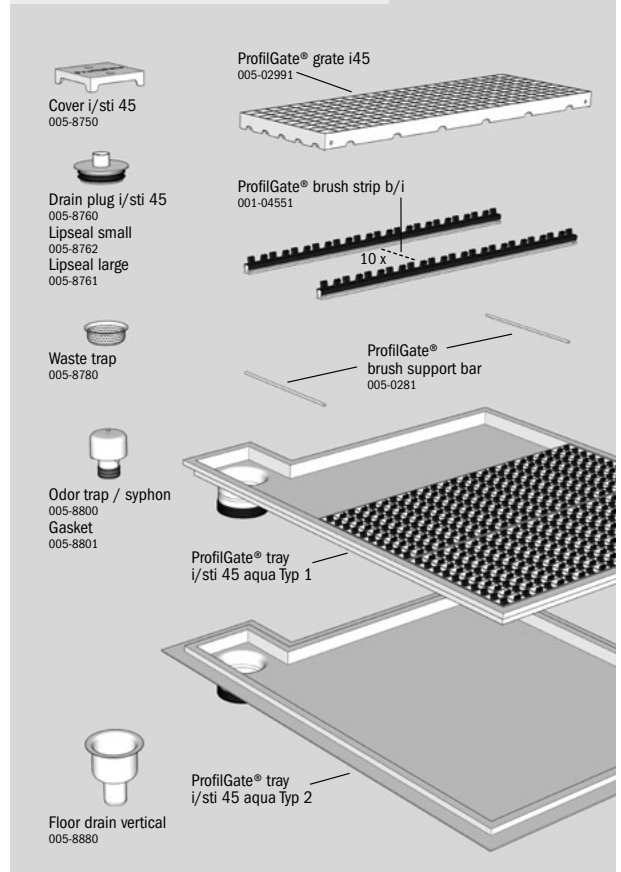

ProfilGate® sti45 aqua with Drain Type A

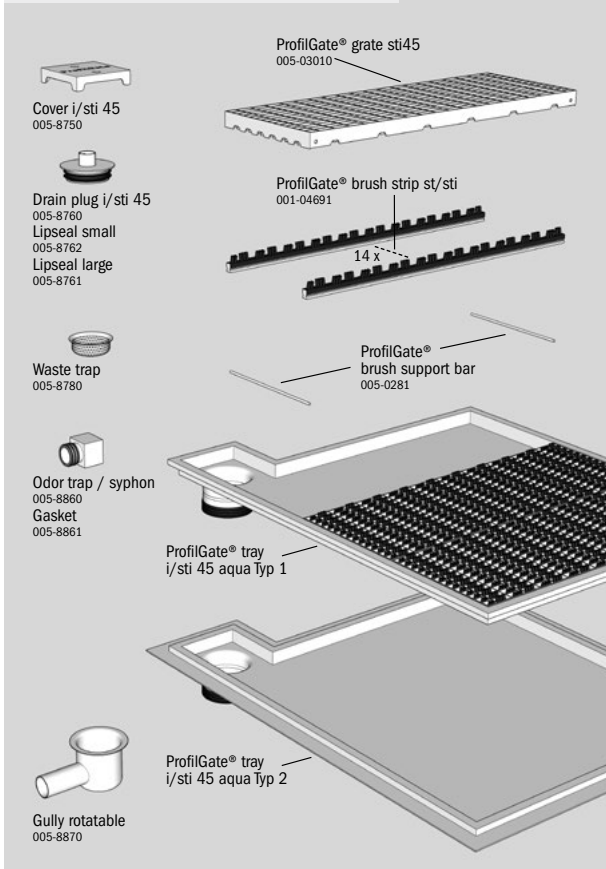

ProfilGate® sti45 aqua with Drain Type B

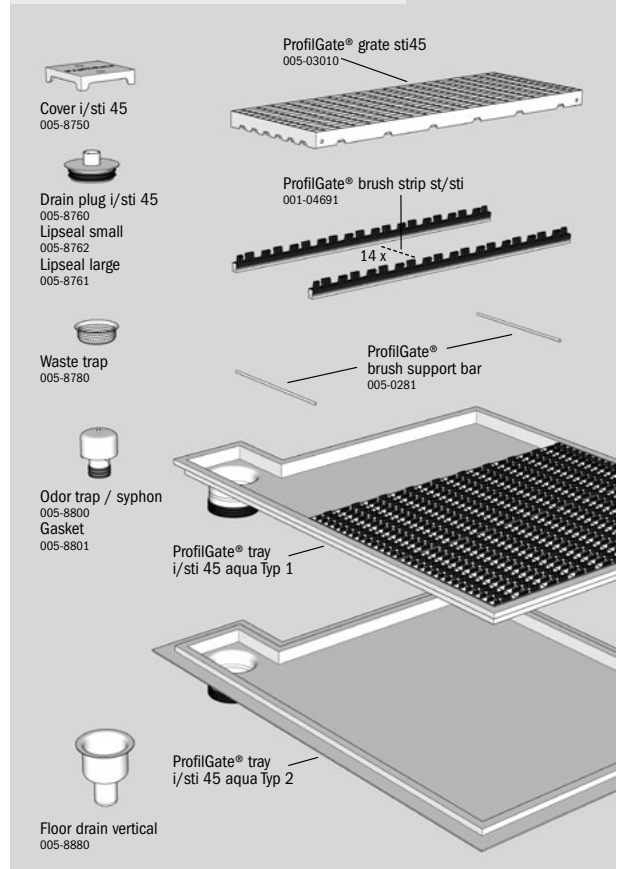

ProfilGate® i55 aqua with Drain Type A

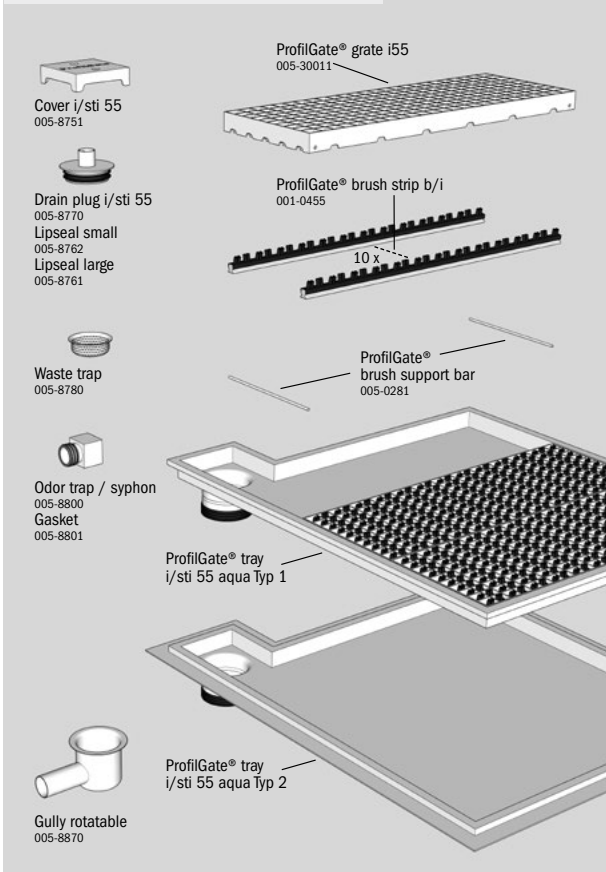

ProfilGate® i55 aqua with Drain Type B

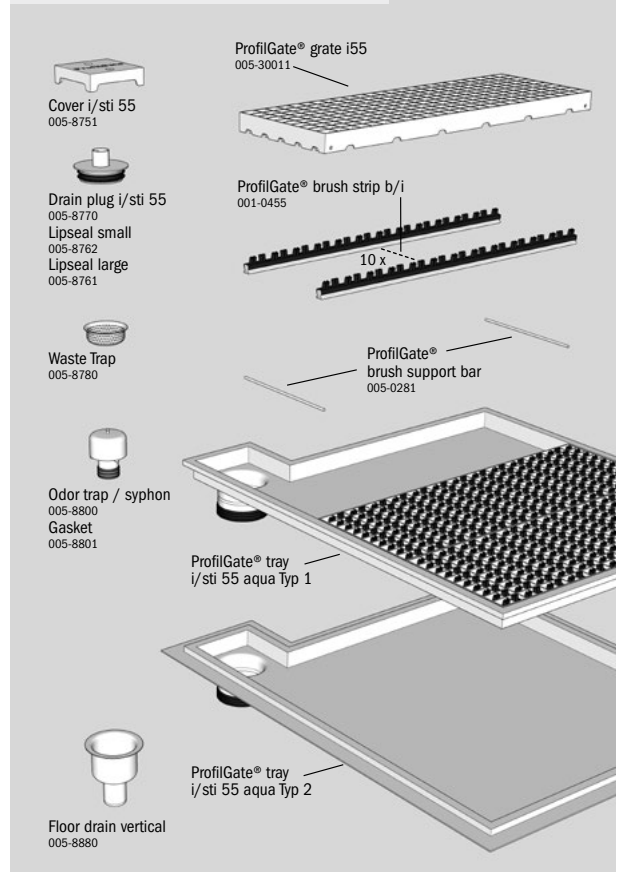

ProfilGate® sti55 aqua with Drain Type A

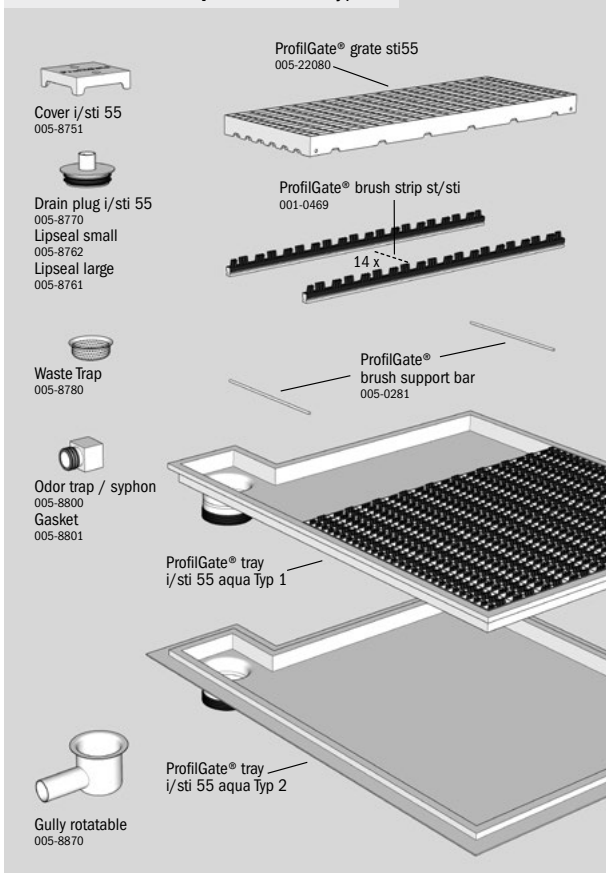

ProfilGate® sti55 aqua with Drain Type B

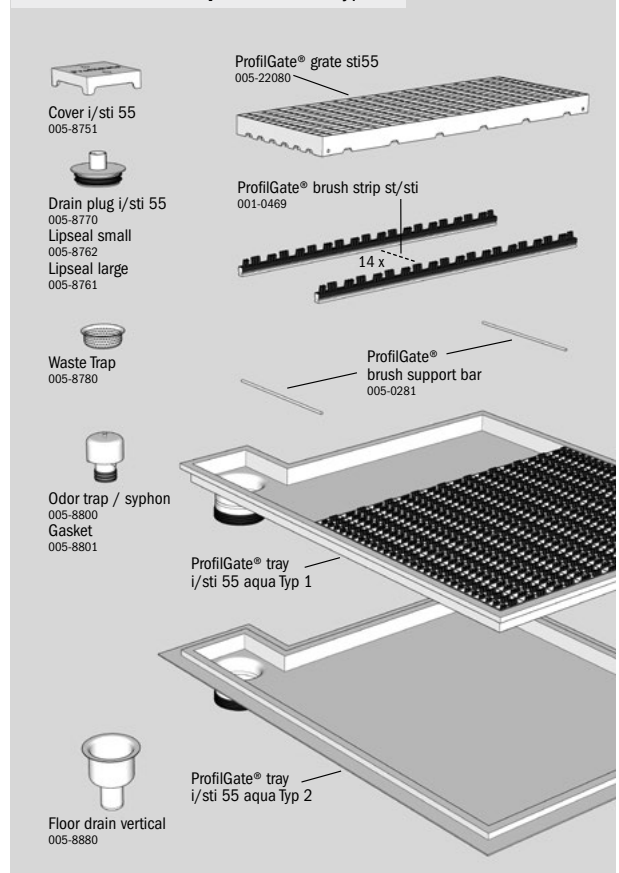

IMPORTANT – READ FIRST

Only start up the cleaning field after having read and understood these operating instructions. Should you need clarification, or have any questions, we are always available to help.

ProfilGate® tire cleaning fields from the HEUTE Maschinenfabrik are built and tested in accordance with the latest safety regulations. The proper function and operational safety of the system can be guaranteed only, if the generally applicable safety precautions and system-specific safety information in these operating instructions are observed during use. The guarantee will lapse in case of damage caused by ignoring these operating instructions. The manufacturer shall not accept any liability for personal injury or damage to property arising from the aforesaid. In the event of problems, please immediately contact our service department.

Intended use

ProfilGate® tire cleaning fields serve for the cleaning of contact surfaces from tires, wheels and other wheels from vehicles, plus from shoe soles from pedestrians through a mechanical grinding action. Other use is not permitted!

Only the brush strips and spare parts approved by the manufacturer may be used for the cleaning field.

Foreseeable misuse

The tire cleaning fields must not be used for:

- Cleaning objects other than tires, wheels or shoe soles.
- Use as hand-held device to process surfaces.
- Usage under the addition of caustic liquids.

Safety instructions



Read these operating instructions precisely and follow the instructions for correct installation and use.

If non-original spare parts are used or non-approved changes are made to the cleaning field, the manufacturer's/distributor's guarantee lapses immediately.

The cleaning field may only be used by authorized and instructed persons.

The cleaning field may not be changed or modified, because this may lead to risks such as reduced carrying capacity or lowered slip inhibition. Maintenance and repair must be carried out exclusively by persons authorised for the purpose, using original parts only.

The user is responsible for any personal injury and damage to property that arise due to improper use as well as user and/or installation errors for the cleaning field.

When installed in commercial facilities, comply with the industrial safety regulation applicable on site and accident prevention regulations issued by the professional associations.

With a level installation, ensure that there are no edges or gaps between the trays.



Tripping hazard - Ensure that the grates are laid level in the trays.

Visibly mark the above floor installations.

Only wear flat and solid footwear when crossing the cleaning field. Never wear shoes that can get stuck in the grates, for example, pumps.

Slip hazard - Pay attention to frozen liquids in the area of the cleaning field with ambient temperatures below 0° C.

Cross the cleaning field with a maximum speed of up to 6 km/h / 4 mph.

You should refrain from turning, braking and strong acceleration on the cleaning field, because this impairs the lifespan of the brush strips.

Do not pull or slide any objects over the cleaning field, because this may cause damage to the brush strips and grates.

Make sure that a usage by children, especially unsupervised, is ruled out. Make sure that any contact between animals and the cleaning field is ruled out.

Never drink liquid from the ProfilGate® trays. They may contain cleaning agents, dirt and other poisonous substances. The water used in ProfilGate® is normally not drinking water.

Do not reach into the system while it is in operation. Make sure that no vehicle can pass the cleaning field before you conduct any cleaning/maintenance work.

Before cleaning, make sure to visibly guard off the area and ensure that no vehicles or people pass the area.

Wear corresponding protective equipment when working with the cleaning field, specifically during cleaning.

Injury hazard - only lift the grates with protective gloves and make sure that the lifted grates cannot fall down.

Foot protection - wear safety shoes to prevent foot injuries through falling heavy components.

Hand protection - wear protective gloves to prevent hand injuries through contact with dirt or while lifting components.

Eye protection - wear protective goggles to prevent dirt particles from getting in your eyes.

Breathing protection - wear breathing protection to prevent dirt particles from getting in your respiratory system.

Never leave a tray from the system open or uncovered. This causes a dangerous decline/pit.

Do not use any abrasive or aggressive cleaning agents, because these may corrode the installed components and damage them.

Welcome

We thank you for purchasing one of our ProfilGate® wheel cleaning fields. These operating instructions provide important information about commissioning, operation and maintenance.

Scope of delivery

Grate with clamped brush strips, stainless steel trays, operating instructions, warning sign, if applicable, accessories such as hooks, lifting equipment and cleaning field.

Declaration of conformity

The manufacturer hereby confirms that the products of the type ProfilGate® described in the following comply with the following technical specifications:

- Stainless steel tray: DIN EN 10088-2, DIN EN 1302, DIN EN ISO 13920 AE, DIN ISO 2768-1 mk, DIN 8586, EN ISO 4063 process 141
- Pressure welded gratings: DIN EN ISO 1461, EN 1090, DIN 24537-1, RAL GZ 638, BGI 588, DIN EN ISO 1461
- Fibreglass-reinforced synthetic gratings: DIN EN ISO 16901, ISO 1183, IEC 60695-11-10
- Brush strip: UL 94 V-0 (brush body), UL 94 V-2 (bristles), RL 2002/72/EG, VO (EG) 1935/2004, FDA Title 21, part 177. ff

Authorized representative Steffen Moersch, same address as manufacturer.

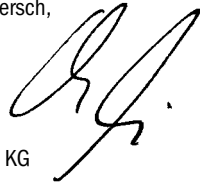

Christian Löwe (Managing Director)
HEUTE Maschinenfabrik GmbH & Co. KG

Environmental protection

Disposal of the transport packaging

Our packaging materials are recyclable. Please dispose of the packaging in an environmentally friendly manner. The packaging must not be given to children to play with. There is a risk of suffocation caused by cardboard packaging or plastic films.

Disposal of the product

Valuable raw materials can be recovered by environmentally friendly disposal. Please inform yourself about the current disposal methods by contacting the responsible person in your company or your local authority.

Guarantee

We provide the following guarantees on the components of the ProfilGate® cleaning system*:

Dry cleaning (for b55/ st55/ xs55/ b65 / st65/ xs65)

Tray, grate, quick-release axles 5 years
Brush strips 1 year

Wet cleaning and disinfection (for i45/ sti45/ i55/ sti55)

Tray, grate, quick-release axles 5 years
Brush strips 1 year

*This requires the proper installation, use, care and maintenance of the cleaning system.

Table of contents

Model line	2
Important - read first	32
Intended use	32
Foreseeable misuse	32
Safety instructions	32
Welcome	33
Scope of delivery	33
Declaration of conformity	33
Environmental protection	33
Guarantee	33
Technical data	34
Installation and commissioning	38
Typical configurations	38
Preparation before installation	39
General notes on installation	39
Installation of warning sign	39
Installation of cleaning field	39
Ground level installation	40
Ground level installation of ProfilGate® aqua	42
Installation above ground with entrance and exit ramps	44
Above ground installation with ramps for pedestrians	46
Operation	47
ProfilGate® function in practice	47
ProfilGate® aqua function in practice	47
ProfilGate® DryZone function in practice	47
Cleaning quality	47
Suitability and limits	47
Service and maintenance	48
Control	48
Cleaning	48
Maintenance	48
Recommended service intervals	48
Inspection of brush strips	49
Collect/analyze dirt	49
Cleaning interval table	49
Open grates with ProfilGate® Lifter (1 Person)	50
Open grates with short lifting hooks (2 people)	50
Open grates with long lifting hooks (2 people)	51
Complete cleaning after removing the grate	51
Complete cleaning wet after grate removal	51
Complete cleaning ProfilGate® aqua after grate removal	52
Setting the fill level of ProfilGate® aqua	52
Brush replacement with quick-release axle	53
Trouble shooting	54

Technical data ProfilGate® (except for aqua models)

Model	Width	Length	Height	Grates per segment	Brush strips per grate	Number of grates x weight	Max. permissible total weight	Item No.
b65 1x1	718	980	65	2	10	2 x 29 kg	40 t	005-0750B
b65 1,5x1	1069	980	65	3	10	3 x 29 kg	40 t	005-0110B
b55 1x1	718	980	55	2	10	2 x 27 kg	40 t	005-6750B
b55 1,5x1	1069	980	55	3	10	3 x 27 kg	40 t	005-6110B
st65 1x1	718	980	65	2	14	2 x 31 kg	40 t	005-0790B
st65 1x1	1069	980	65	3	14	3 x 31 kg	40 t	005-2207B
st55 1x1	718	980	55	2	14	2 x 27 kg	40 t	005-2300B
st55 1,5x1	1069	980	55	3	14	3 x 27 kg	40 t	005-2206B
i55 1x1	718	980	55	2	10	2 x 26 kg	10 t	005-3000B
i55 1,5x1	1069	980	55	3	10	3 x 26 kg	10 t	005-3100B
sti55 1x1	718	980	55	2	14	2 x 27 kg	10 t	005-2350B
sti55 1,5x1	1069	980	55	3	14	3 x 27 kg	10 t	005-2360B
b65 go 1x1	718	980	65	2	10	2 x 29 kg	40 t	005-0750GO
b65 go 1,5x1	1069	980	65	3	10	3 x 29 kg	40 t	005-0110GO
b55 go 1x1	718	980	55	2	10	2 x 27 kg	40 t	005-6750GO
b55 go 1,5x1	1069	980	55	3	10	3 x 27 kg	40 t	005-6110GO
st65go 1x1	718	980	65	2	14	2 x 31 kg	40 t	005-0790GO
st65go 1,5x1	1069	980	65	3	14	3 x 31 kg	40 t	005-2207GO
st55go 1x1	718	980	55	2	14	2 x 27 kg	40 t	005-2300GO
st55go 1,5x1	1069	980	55	3	14	3 x 27 kg	40 t	005-2206GO
i55go 1x1	718	980	55	2	10	2 x 26 kg	10 t	005-3000GO
i55go 1,5x1	1069	980	55	3	10	3 x 26 kg	10 t	005-3100GO
sti55go 1x1	718	980	55	2	10	2 x 27 kg	10 t	005-2350GO
sti55go 1,5x1	1069	980	55	3	10	3 x 27 kg	10 t	005-2360GO
xs65 1x1	718	980	65	2	14	2 x 32 kg	40 t	005-0791B
xs65 1,5x1	1069	980	65	3	14	3 x 32 kg	40 t	005-22071B
xs55 1x1	718	980	55	2	14	2 x 29 kg	40 t	005-2301B
xs55 1,5x1	1069	980	55	3	14	3 x 29 kg	40 t	005-22061B
xs65 go 1x1	718	980	65	2	14	2 x 32 kg	40 t	005-0791GO
xs65 go 1,5x1	1069	980	65	3	14	3 x 32 kg	40 t	005-22071GO
st55go 1x1	718	980	55	2	14	2 x 27 kg	40 t	005-2300GO
xs65 go 1,5x1	1069	980	65	3	14	3 x 32 kg	40 t	005-22071GO

Technical data ProfilGate® ramps for above floor use

Ramp model	Ramp type	Width	Length	Height	Material	Weight	Max. permissible total weight	Item No.
b/st/xs65 1x1	Ramp F (Front)	718	1500	65	Bulb plate, galvanized	53 kg	10 t	005-0840
b/st/xs65 1,5x1	Ramp F (Front)	1070	1500	65	Bulb plate, galvanized	80 kg	10 t	005-0845
b/st/xs55 1x1	Ramp F (Front)	718	1200	55	Bulb plate, galvanized	38 kg	10 t	005-6040
b/st/xs55 1,5x1	Ramp F (Front)	1070	1200	55	Bulb plate, galvanized	57 kg	10 t	005-6045
b/st65/xs go 1x1	Ramp F (Front)	719	300	65	Bulb plate, galvanized	6 kg	250 kg	005-6420
b/st65/xs go 1,5x1	Ramp L (Front)	1070	300	65	Bulb plate, galvanized	13 kg	250 kg	005-6440
b/st65/xs go 1x1	Ramp S (side)	981	300	65	Bulb plate, galvanized	12 kg	250 kg	005-6410
b/st65/xs go 1x1	Ramp C (corner)	300	300	65	Bulb plate, galvanized	1 kg	250 kg	005-6430
b/st/xs55 go 1x1	Ramp F (Front)	719	250	55	Bulb plate, galvanized	5 kg	250 kg	005-6320
b/st/xs55 go 1,5x1	Ramp L (Front)	1070	250	55	Bulb plate, galvanized	8 kg	250 kg	005-6311
b/st/xs55 go 1x1	Ramp S (side)	981	250	55	Bulb plate, galvanized	11 kg	250 kg	005-6310
b/st/xs55 go 1x1	Ramp C (corner)	250	250	55	Bulb plate, galvanized	1 kg	250 kg	005-6330
i/sti55 go 1x1	Ramp F (Front)	719	250	55	VA bulb plate	5 kg	250 kg	005-3020
i/sti55 go 1,5x1	Ramp L (Front)	1070	250	55	VA bulb plate	7 kg	250 kg	005-3040
i/sti55 go 1x1	Ramp S (side)	981	250	55	VA bulb plate	11 kg	250 kg	005-3010
i/sti55 go 1x1	Ramp C (corner)	250	250	55	VA bulb plate	1 kg	250 kg	005-3030

EN

Technical data ProfilGate® aqua TYP 1 with border profile

Model	Width	Length	Height	Grates per segment	Brush strips per grate	Number of grates x weight	Volume appr.	Max. permissible total weight	Item No.
i45 aqua 1.5x1	1119	1026	45	3	10	3 x 21 kg	22 liters	10 t	005-5020B
i45 aqua 2x1	1473	1026	45	4	10	4 x 21 kg	29 liters	10 t	005-5030B
i45 aqua 2.5x1	1829	1026	45	5	10	5 x 21 kg	36 liters	10 t	005-5040B
i45 aqua 3x1	2183	1026	45	6	10	6 x 21 kg	43 liters	10 t	005-5050B
i45 aqua 1x2	764	1997	45	4	10	4 x 21 kg	29 liters	10 t	005-5080B
i45 aqua 1.5x2	1119	1997	45	6	10	6 x 21 kg	43 liters	10 t	005-5090B
i45 aqua 2x2	1473	1997	45	8	10	8 x 21 kg	57 liters	10 t	005-5100B
i45 aqua 2.5x2	1829	1997	45	10	10	10 x 21 kg	71 liters	10 t	005-5110B
i45 aqua 3x2	2183	1997	45	12	10	12 x 21 kg	85 liters	10 t	005-5120B
i45 aqua 1.5x3	1119	2967	45	9	10	9 x 21 kg	64 liters	10 t	005-5160B
i45 aqua 2x3	1473	2967	45	12	10	12 x 21 kg	85 liters	10 t	005-5170B
i45 aqua 2.5x3	1829	2967	45	15	10	15 x 21 kg	106 liters	10 t	005-5180B
sti45 aqua 1.5x1	1119	1026	45	3	14	3 x 22 kg	21.25 liters	10 t	005-6020B
sti45 aqua 2x1	1473	1026	45	4	14	4 x 22 kg	28 liters	10 t	005-6030B
sti45 aqua 2.5x1	1829	1026	45	5	14	5 x 23 kg	34.75 liters	10 t	005-6040B
sti45 aqua 3x1	2183	1026	45	6	14	6 x 23 kg	41.5 liters	10 t	005-6050B
sti45 aqua 1x2	764	1997	45	4	14	4 x 23 kg	28 liters	10 t	005-6080B
sti45 aqua 1.5x2	1119	1997	45	6	14	6 x 23 kg	41.5 liters	10 t	005-6090B
sti45 aqua 2x2	1473	1997	45	8	14	8 x 23 kg	55 liters	10 t	005-6100B
sti45 aqua 2.5x2	1829	1997	45	10	14	10 x 23 kg	68.5 liters	10 t	005-6130B
sti45 aqua 3x2	2183	1997	45	12	14	12 x 23 kg	82 liters	10 t	005-6120B
sti45 aqua 1.5x3	1119	2967	45	9	14	9 x 23 kg	61.75 liters	10 t	005-6160B
sti45 aqua 2x3	1473	2967	45	12	14	12 x 23 kg	82 liters	10 t	005-6170B
sti45 aqua 2.5x3	1829	2967	45	15	14	15 x 23 kg	102.25 liters	10 t	005-6180B
i55 aqua 1.5x1	1115	1026	55	3	10	3 x 26 kg	31.5 liters	10 t	005-7020B
i55 aqua 2x1	1470	1026	55	4	10	4 x 26 kg	41.5 liters	10 t	005-7030B
i55 aqua 2.5x1	1824	1026	55	5	10	5 x 26 kg	51.5 liters	10 t	005-7040B
i55 aqua 3x1	2177	1026	55	6	10	6 x 26 kg	61.5 liters	10 t	005-7050B
i55 aqua 1x2	764	1995	55	4	10	4 x 26 kg	41.5 liters	10 t	005-7080B
i55 aqua 1.5x2	1115	1995	55	6	10	6 x 26 kg	61.5 liters	10 t	005-7090B
i55 aqua 2x2	1470	1995	55	8	10	8 x 26 kg	81.5 liters	10 t	005-7100B
i55 aqua 2.5x2	1824	1995	55	10	10	10 x 26 kg	101.5 liters	10 t	005-7110B
i55 aqua 3x2	2177	1995	55	12	10	12 x 26 kg	121.5 liters	10 t	005-7120B
i55 aqua 1.5x3	1115	2963	55	9	10	9 x 26 kg	91.5 liters	10 t	005-7160B
i55 aqua 2x3	1470	2963	55	12	10	12 x 26 kg	121.5 liters	10 t	005-7170B
i55 aqua 2.5x3	1824	2963	55	15	10	15 x 26 kg	151.5 liters	10 t	005-7180B
sti55 aqua 1.5x1	1115	1026	55	3	14	3 x 27 kg	30.75 liters	10 t	005-8020B
sti55 aqua 2x1	1470	1026	55	4	14	4 x 27 kg	40.5 liters	10 t	005-8030B
sti55 aqua 2.5x1	1824	1026	55	5	14	5 x 27 kg	50.25 liters	10 t	005-8040B
sti55 aqua 3x1	2177	1026	55	6	14	6 x 27 kg	60 liters	10 t	005-8050B
sti55 aqua 1x2	764	1995	55	4	14	4 x 27 kg	40.5 liters	10 t	005-8080B
sti55 aqua 1.5x2	1115	1995	55	6	14	6 x 27 kg	60 liters	10 t	005-8090B
sti55 aqua 2x2	1470	1995	55	8	14	8 x 27 kg	79.5 liters	10 t	005-8100B
sti55 aqua 2.5x2	1824	1995	55	10	14	10 x 27 kg	99 liters	10 t	005-8110B
sti55 aqua 3x2	2177	1995	55	12	14	12 x 27 kg	118.5 liters	10 t	005-8120B
sti55 aqua 1.5x3	1115	2963	55	9	14	9 x 27 kg	89.25 liters	10 t	005-8160B
sti55 aqua 2x3	1470	2963	55	12	14	12 x 27 kg	118.5 liters	10 t	005-8170B
sti55 aqua 2.5x3	1824	2963	55	15	14	15 x 27 kg	147.75 liters	10 t	005-8180B

Technical data ProfilGate® aqua TYPE 2 with insulating flange

Model	Width	Length	Height	Grates per segment	Brush strips per grate	Number of grates x weight	Volume appr.	Max. permissible total weight	Item No.
i45 aqua 1.5x1	1219	1126	45	3	10	3 x 21 kg	22 liters	10 t	005-5025B
i45 aqua 2x1	1573	1126	45	4	10	4 x 21 kg	29 liters	10 t	005-5035B
i45 aqua 2.5x1	1929	1126	45	5	10	5 x 21 kg	36 liters	10 t	005-5045B
i45 aqua 3x1	2283	1126	45	6	10	6 x 21 kg	43 liters	10 t	005-5055B
i45 aqua 1x2	864	2097	45	4	10	4 x 21 kg	29 liters	10 t	005-5085B
i45 aqua 1.5x2	1219	2097	45	6	10	6 x 21 kg	43 liters	10 t	005-5095B
i45 aqua 2x2	1573	2097	45	8	10	8 x 21 kg	57 liters	10 t	005-5105B
i45 aqua 2.5x2	1929	2097	45	10	10	10 x 21 kg	71 liters	10 t	005-5115B
i45 aqua 3x2	2283	2097	45	12	10	12 x 21 kg	85 liters	10 t	005-5125B
i45 aqua 1.5x3	1219	3067	45	9	10	9 x 21 kg	64 liters	10 t	005-5165B
i45 aqua 2x3	1573	3067	45	12	10	12 x 21 kg	85 liters	10 t	005-5175B
i45 aqua 2.5x3	1929	3067	45	15	10	15 x 21 kg	106 liters	10 t	005-5185B
sti45 aqua 1.5x1	1219	1126	45	3	14	3 x 22 kg	21.25 liters	10 t	005-6025B
sti45 aqua 2x1	1573	1126	45	4	14	4 x 22 kg	28 liters	10 t	005-6035B
sti45 aqua 2.5x1	1929	1126	45	5	14	5 x 23 kg	34.75 liters	10 t	005-6045B
sti45 aqua 3x1	2283	1126	45	6	14	6 x 23 kg	41.5 liters	10 t	005-6055B
sti45 aqua 1x2	864	2097	45	4	14	4 x 23 kg	28 liters	10 t	005-6085B
sti45 aqua 1.5x2	1219	2097	45	6	14	6 x 23 kg	41.5 liters	10 t	005-6095B
sti45 aqua 2x2	1573	2097	45	8	14	8 x 23 kg	55 liters	10 t	005-6105B
sti45 aqua 2.5x2	1929	2097	45	10	14	10 x 23 kg	68.5 liters	10 t	005-6135B
sti45 aqua 3x2	2283	2097	45	12	14	12 x 23 kg	82 liters	10 t	005-6125B
sti45 aqua 1.5x3	1219	3067	45	9	14	9 x 23 kg	61.75 liters	10 t	005-6165B
sti45 aqua 2x3	1573	3067	45	12	14	12 x 23 kg	82 liters	10 t	005-6175B
sti45 aqua 2.5x3	1929	3067	45	15	14	15 x 23 kg	102.25 liters	10 t	005-6185B
i55 aqua 1.5x1	1215	1126	55	3	10	3 x 26 kg	31.5 liters	10 t	005-7025B
i55 aqua 2x1	1570	1126	55	4	10	4 x 26 kg	41.5 liters	10 t	005-7035B
i55 aqua 2.5x1	1924	1126	55	5	10	5 x 26 kg	51.5 liters	10 t	005-7045B
i55 aqua 3x1	2277	1126	55	6	10	6 x 26 kg	61.5 liters	10 t	005-7055B
i55 aqua 1x2	864	2095	55	4	10	4 x 26 kg	41.5 liters	10 t	005-7085B
i55 aqua 1.5x2	1215	2095	55	6	10	6 x 26 kg	61.5 liters	10 t	005-7095B
i55 aqua 2x2	1570	2095	55	8	10	8 x 26 kg	81.5 liters	10 t	005-7105B
i55 aqua 2.5x2	1924	2095	55	10	10	10 x 26 kg	101.5 liters	10 t	005-7115B
i55 aqua 3x2	2277	2095	55	12	10	12 x 26 kg	121.5 liters	10 t	005-7125B
i55 aqua 1.5x3	1215	3063	55	9	10	9 x 26 kg	91.5 liters	10 t	005-7165B
i55 aqua 2x3	1570	3063	55	12	10	12 x 26 kg	121.5 liters	10 t	005-7175B
i55 aqua 2.5x3	1924	3063	55	15	10	15 x 26 kg	151.5 liters	10 t	005-7185B
sti55 aqua 1.5x1	1215	1126	55	3	14	3 x 27 kg	30.75 liters	10 t	005-8025B
sti55 aqua 2x1	1570	1126	55	4	14	4 x 27 kg	40.5 liters	10 t	005-8035B
sti55 aqua 2.5x1	1924	1126	55	5	14	5 x 27 kg	50.25 liters	10 t	005-8045B
sti55 aqua 3x1	2277	1126	55	6	14	6 x 27 kg	60 liters	10 t	005-8055B
sti55 aqua 1x2	864	2095	55	4	14	4 x 27 kg	40.5 liters	10 t	005-8085B
sti55 aqua 1.5x2	1215	2095	55	6	14	6 x 27 kg	60 liters	10 t	005-8095B
sti55 aqua 2x2	1570	2095	55	8	14	8 x 27 kg	79.5 liters	10 t	005-8105B
sti55 aqua 2.5x2	1924	2095	55	10	14	10 x 27 kg	99 liters	10 t	005-8115B
sti55 aqua 3x2	2277	2095	55	12	14	12 x 27 kg	118.5 liters	10 t	005-8125B
sti55 aqua 1.5x3	1215	3063	55	9	14	9 x 27 kg	89.25 liters	10 t	005-8165B
sti55 aqua 2x3	1570	3063	55	12	14	12 x 27 kg	118.5 liters	10 t	005-8175B
sti55 aqua 2.5x3	1924	3063	55	15	14	15 x 27 kg	147.75 liters	10 t	005-8185B

Installation and commissioning

ProfilGate® cleaning fields eliminate dirt build-ups on tires, wheels and shoes. They can be used for factory traffic from outdoor areas to indoor areas as well as between different areas within a factory. This minimizes carryover and the system actively contributes to the cleanliness of your company.

The system is based on special brush strips that are clamped into the grate. The brush strips actively work due to their inherent tension and angled position of the bristles and thereby result in a mechanical cleaning of the contact surfaces when covered. The dirt is rubbed off and collected in the trays below. Later, the dirt can simply be brushed or vacuumed out and it will not land in the areas behind it.

Typical configurations



Level installation – connection outside-inside

A typical ProfilGate® field is made up of about 3-4 segments wide and 4-5 segments long. It is inserted level so that it is possible to drive over it without any noticeable differences compared to normal flooring. The field should only be driven on in a straight direction and this being in the installation direction of the brush strips.



Ground level installation - wet cleaning ProfilGate® i45/sti45, i55/sti55 aqua

For the models listed above, the trays can be filled with cleaning or disinfecting liquid. Through the capillary effect of the bristles, the contact surfaces are moistened with cleaning liquid upon passing. The liquid can be replaced through a drain or a wet vacuum.



Lay above ground – ProfilGate® b/st55/xs go with ramps

If a ground level installation is not possible, special ProfileGate® go ramps are available, which only need a little space in pedestrian passages.

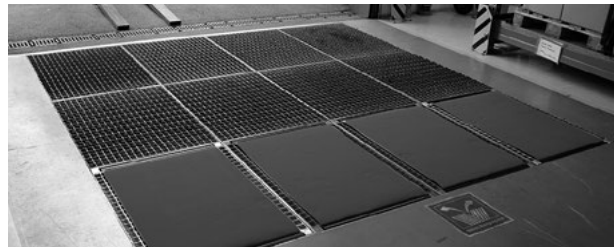

Level installation –

Combination ProfilGate® and ProfilGate® DryZone

A ProfilGate® cleaning field can be combined with special ProfilGate® DryZone segments to remove moisture. The inserted fleece absorbs the moisture from the contact surfaces.

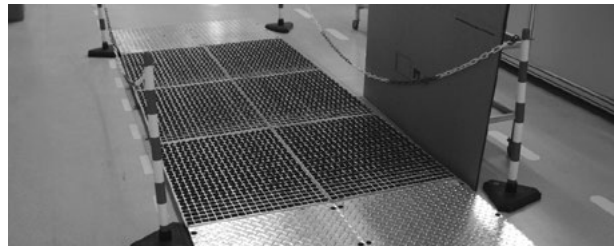

Laying above ground – driving over ramps

It is possible to operate the cleaning field above ground for test purposes. The segments are placed on the ground and fixed in place through ramps in the front and back as well as through side fixing corners. This construction minimizes damage to the floor, but we only recommend it in cases of exception, because this results in additional sources of hazard and disadvantages. Make sure that the edges of the cleaning field are secured against being driven on or stepped on from the side (warning tape, chain barrier, etc.).



Grounding in explosion-protected or ESD areas

If the ProfilGate® system is installed in an area that requires special conditions regarding electrostatic charges (for example, “ex-protected” or “ESD” area), a separate grounding of the trays is required. On request, one or multiple threaded bolts may be attached to the trays for connection with a grounding system to allow for reliable potential equalization. In this case, the individual trays should additionally be connected to each other for conduction (for example, through soldering or welding on the tray edge).

Combination with induction loops

Since ProfilGate® contains metallic components, an existing induction loop is permanently occupied through the installation and its function is no longer present. To not lose the effect of ProfilGate®, you can either

- lay the wheel cleaning field with a little distance to the induction loop,
- or adjust the frequency of the induction loop to the occupation by the wheel cleaning field.

Should only the installation of an induction loop be possible and the induction loop is not adjusted correspondingly, we recommend using a sensor that is not installed in the ground (for example, light barrier or radar).

Preparation before installation

Before you begin with the installation of a ProfilGate® system, you should follow the following steps to avoid errors and achieve an optimal result.

1. Is the delivery set for this installation site?

Once you have informed us of a concrete installation site with the order, it will be noted on the address label. Contact the responsible planner in your company if uncertain.

2. Check the completeness of the delivery

Make sure that there are enough and suitable grates and trays for the planned area so that the installation can occur completely and without delay.

3. Unpack and clean delivered trays

Carefully remove the packaging materials and, if necessary, collections of dirt so there is no unevenness after installation.

4. Study all installation instructions

Before installation, all people involved should carefully study all required instructions, for example, also all safety/handling notes of the materials being used.

General notes on installation

1. Principle

Let the ProfilGate® level into the ground or install the system above ground for test purposes. On the following pages you will find the different types of installation shown schematically depending on the model.

2. Dimensions

Calculate the required area and, if necessary, the installation depth before beginning construction. You can calculate all relevant dimensions with the aid of the calculation examples (page 40, 42 and 44) and the affiliated table. In this step, you can also calculate the space needed for levelling compound, adhesives and filler corresponding to the local circumstances.

3. Static

ProfilGate® is normally installed in or on concrete floors. The design and thickness must also satisfy the required load capacity (for example, $x \text{ t/qm}$) after installation. This applies in particular to the ground level installation variant where the static of the floor is influenced greatly by removing material. Please ask the responsible architects and/or structural engineers for more information and approvals.

4. Levelling compound, adhesive and filler

With all construction materials being used, pay attention to the suitability and application provisions from the respective manufacturers, in particular for levelling compound, adhesive and filler.

Installation of warning sign

Each ProfilGate® field is delivered with a warning sign. Due to work safety reasons, the warning sign must be installed in an easily visible place before commissioning the ProfilGate® cleaning field in a radius of 5 m.

Fig. 01



1. Find a smooth wall surface directly near the cleaning field that is located at eye-level. Clean the surface to be affixed, align the warning sign and affix it.

Attachment cleaning field (optional)

On request, we will deliver a cleaning field with control sheets (additional article, at a cost). This illustrates the correct cleaning of the ProfilGate® cleaning field.

Fig. 02



1. Find a smooth wall surface directly near the cleaning field that is located at eye-level. Align the cleaning field.

Fig. 03



2. Screw the cleaning field on to the wall.

Ground level installation

Calculation of pit dimensions using the example of a ProfilGate® b65 2x3 fields. You will find the corresponding values in the "Technical data" table (see page 34) for your individual configuration.

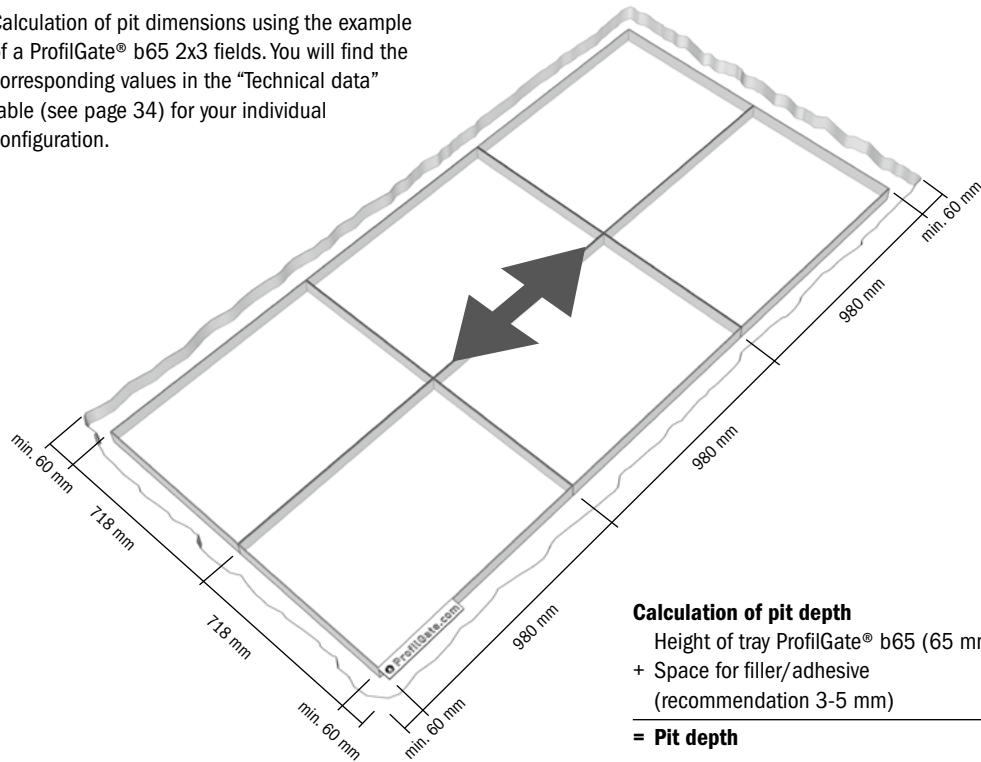

Calculation of pit width

Gap left (recommendation 60-200 mm)	min. 60 mm
+ Number x width ProfilGate® b65 (2 x 718 mm)	1436 mm
+ Joint right (recommendation 60-200 mm)	min. 60 mm
= Pit width	min. 1556 mm

Calculation of pit depth

Height of tray ProfilGate® b65 (65 mm)	65 mm
+ Space for filler/adhesive (recommendation 3-5 mm)	min. 3 mm
= Pit depth	min. 68 mm

Calculation of pit length

Joint front (recommendation 60-200 mm)	min. 60 mm
+ Number x length ProfilGate® b65 (3 x 980 mm)	2940 mm
+ Joint rear (recommendation 60-200 mm)	min. 60 mm
= Pit length	min. 3060 mm

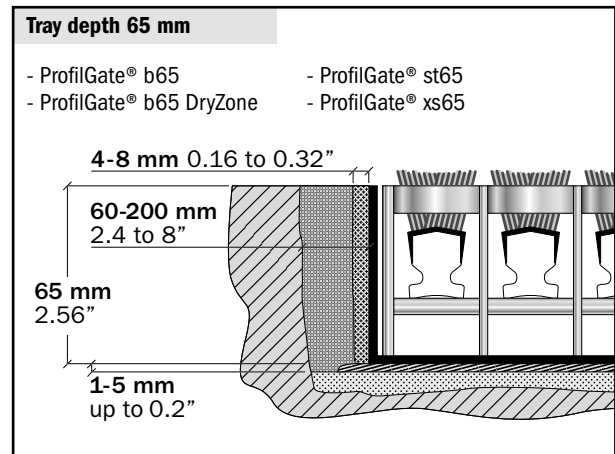
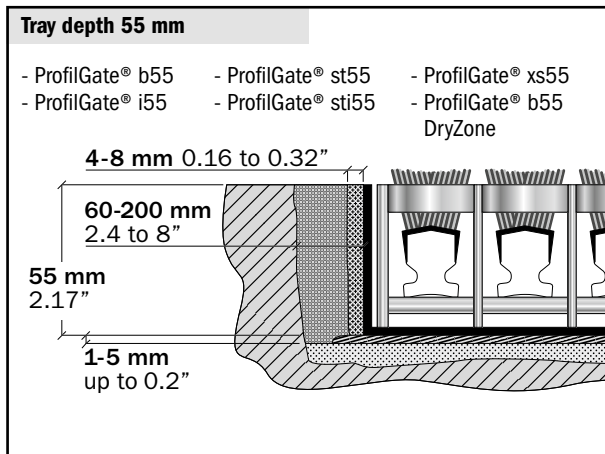

Tray



Grate



Filler/adhesive 1-5 mm under the tray



Joint filling 60 - 200 mm around the entire Cleaning field (outer edge)



Levelling compound



Optional according to manufacturer's recommendation of the edge grouting material used: maintenance joint of 4-8 mm polyurethane

Ground level installation

- ProfilGate® b55
- ProfilGate® i55
- ProfilGate® st55
- ProfilGate® sti55
- ProfilGate® xs55
- ProfilGate® b65
- ProfilGate® st65
- ProfilGate® xs65
- ProfilGate® b55go
- ProfilGate® i55 go
- ProfilGate® st55go
- ProfilGate® sti55go
- ProfilGate® xs55go
- ProfilGate® b65go
- ProfilGate® st65 go
- ProfilGate® xs65go

- 1.** Check the completeness of the delivery and the correct installation site.



- 2.** Create a flat and level pit (see example calculation page 40).

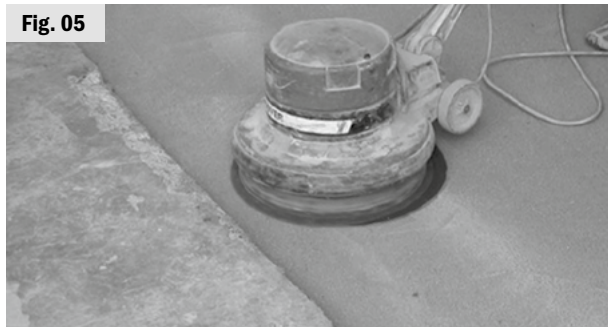

- 3.** Smooth the surface in the pit.

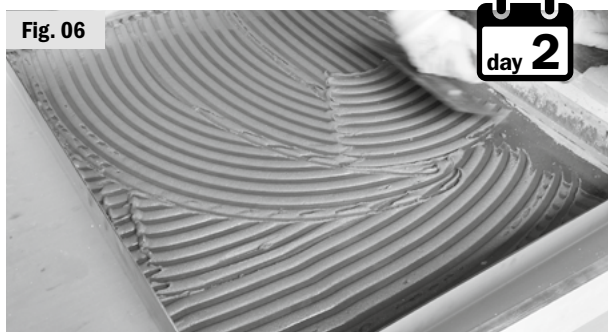

- 4.** Apply adhesive/filler over the entire surface with a notched trowel to the underside of the tray and the floor. In each case in the same trowel direction, but with different trowel teeth for each substrate (observe the processing temperature of the adhesive!). Glue on trays afterwards.



- 5.** Align the trays with each other.

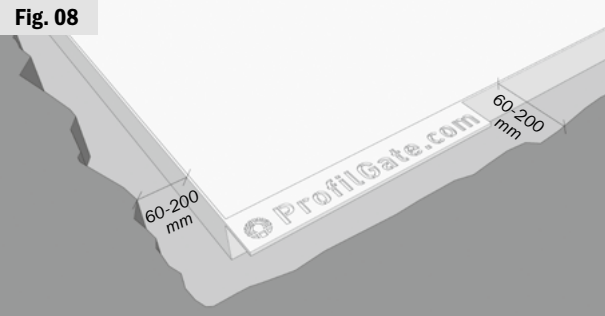

- 6.** Lay the ProfilGate® tray with flag in accordance with the plan.



- 7.** Lay the trays flush with each other, level the heights of the trays ± 0.5 mm. Fasten the trays with each other if necessary.



- 8.** Cast the gap between the edge of the pit and trays so it is flush. Optionally leave open a cavity for a polyurethane filling. Let the filler/adhesive harden.

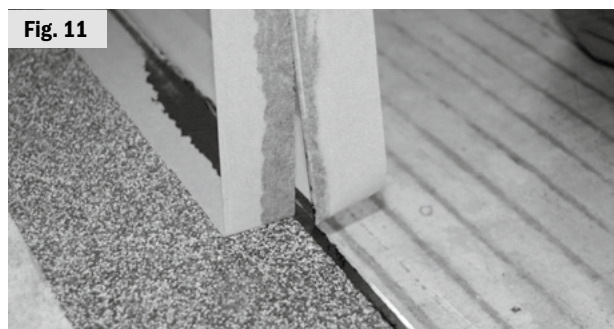

- 9.** Optionally: Fill in the cavity with polyurethane.

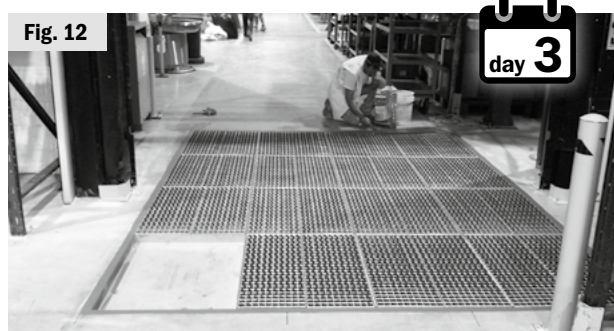

- 10.** Insert the ProfilGate® grate in the trays.

Ground level installation of ProfilGate® aqua

Calculation of pit size using the example of a ProfilGate® i45 aqua 2x2 field. You will find the corresponding values in the "Technical data" table for your individual configuration. (see page 36 / 37).

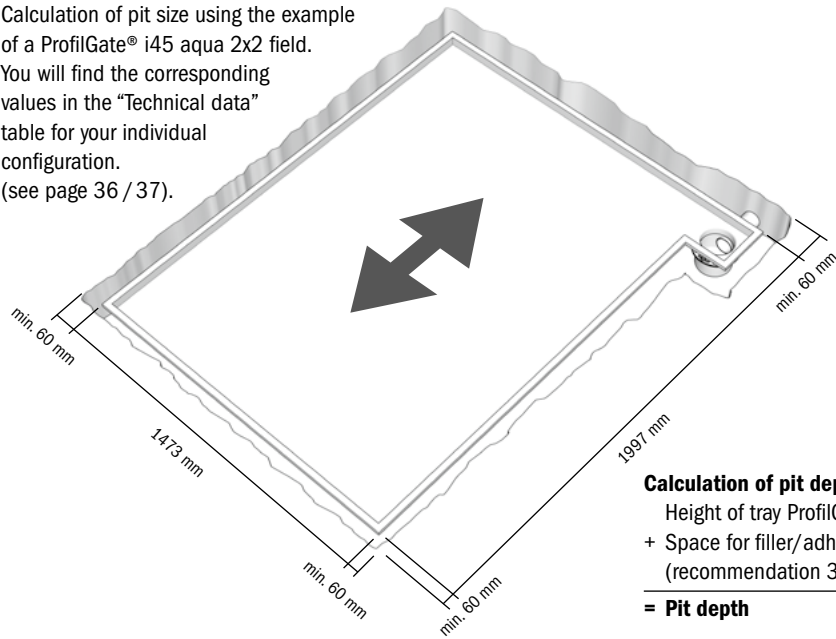

Calculation of pit width

Gap left (recommendation 60-200 mm)	min. 60 mm
+ Number x width ProfilGate® i45 aqua 2x2	1473 mm
+ Joint right (recommendation 60-200 mm)	min. 60 mm
= Pit width	min. 1593 mm

Calculation of pit depth

Height of tray ProfilGate® i45 aqua (45 mm)	45 mm
+ Space for filler/adhesive (recommendation 3-5 mm)	min. 3 mm
= Pit depth	min. 48 mm

Calculation of pit length

Joint front (recommendation 60-200 mm)	min. 60 mm
+ Number x length ProfilGate® i45 aqua 2x2	1997 mm
+ Joint rear (recommendation 60-200 mm)	min. 60 mm
= Pit length	2117 mm

Additionally create a corresponding cavity for the drain and space for the joint (recommendation 60-200 mm).

ProfilGate® aqua tray TYPE 1

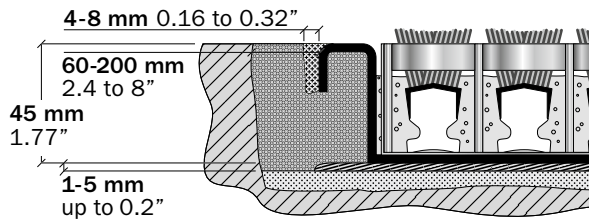

ProfilGate® aqua tray TYPE 2

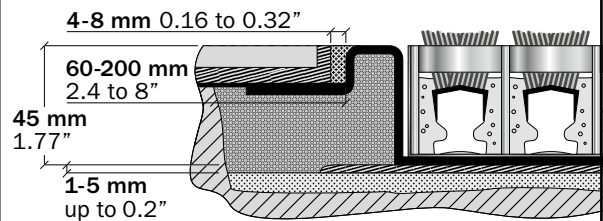

ProfilGate® aqua drain A

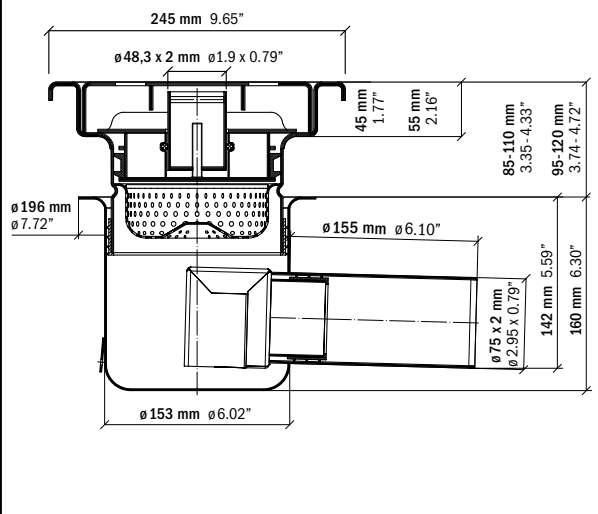

ProfilGate® aqua drain B

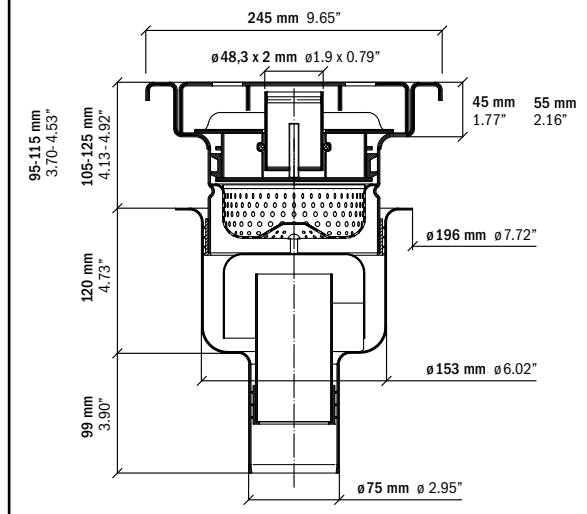

Tray



Grate



Filler/adhesive 1-5 mm under the tray



Joint filling 60 - 200 mm around the entire Cleaning field (outer edge)



Levelling compound



Optional according to manufacturer's recommendation of the edge grouting material used: maintenance joint of 4-8 mm polyurethane

Ground level installation of ProfilGate® aqua

- ProfilGate® i45 aqua TYPE1/2
- ProfilGate® sti45 aqua TYPE1/2
- ProfilGate® i55 aqua TYPE1/2
- ProfilGate® sti55 aqua TYPE1/2

Fig. 13



1. Define pit measurements and cut.

Fig. 14

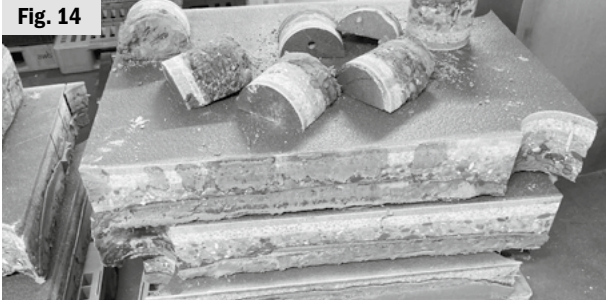

2. Remove floor plate bit by bit.

Fig. 15



3. Prepare pit with self-levelling material to preferred measurements.

Fig. 16



4. Install drain bucket to level and attach the draining system to it.

Fig. 17



5. Apply adhesive/filler over the entire surface with a notched trowel to the underside of the tray and the floor. In each case in the same trowel direction, but with different trowel teeth for each substrate (observe the processing temperature of the adhesive!). Glue on trays afterwards.

Fig. 18

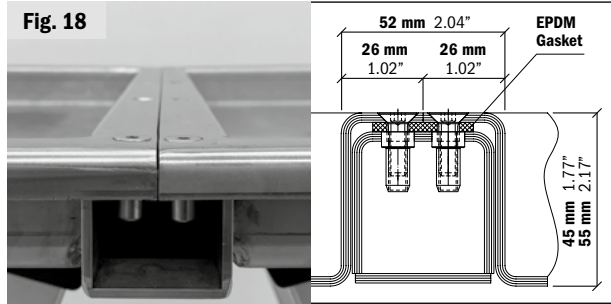

6. In case you install several trays in a row you will have to join the trays using the connecting bar. Make sure that they are levelled.

Fig. 19



7. Attach liquid supply.

Fig. 20



8. Fill in the sites between the stainless steel trays and floor with elastic grout.

Fig. 21



9. Fill in the edges of the pit and make sure the material is connecting the stainless steel trays.

Fig. 22

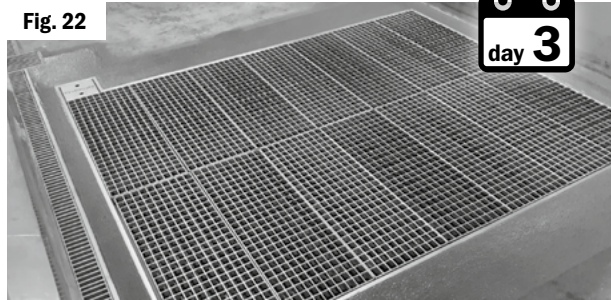

10. Ready installed ProfilGate® aqua field

Installation above ground with entrance and exit ramps

Calculation of installation dimensions using the example of a ProfilGate® b55 2x3 field with ramps. You will find the corresponding values in the "Technical data" table for your individual configuration. (see page 34 / 35).

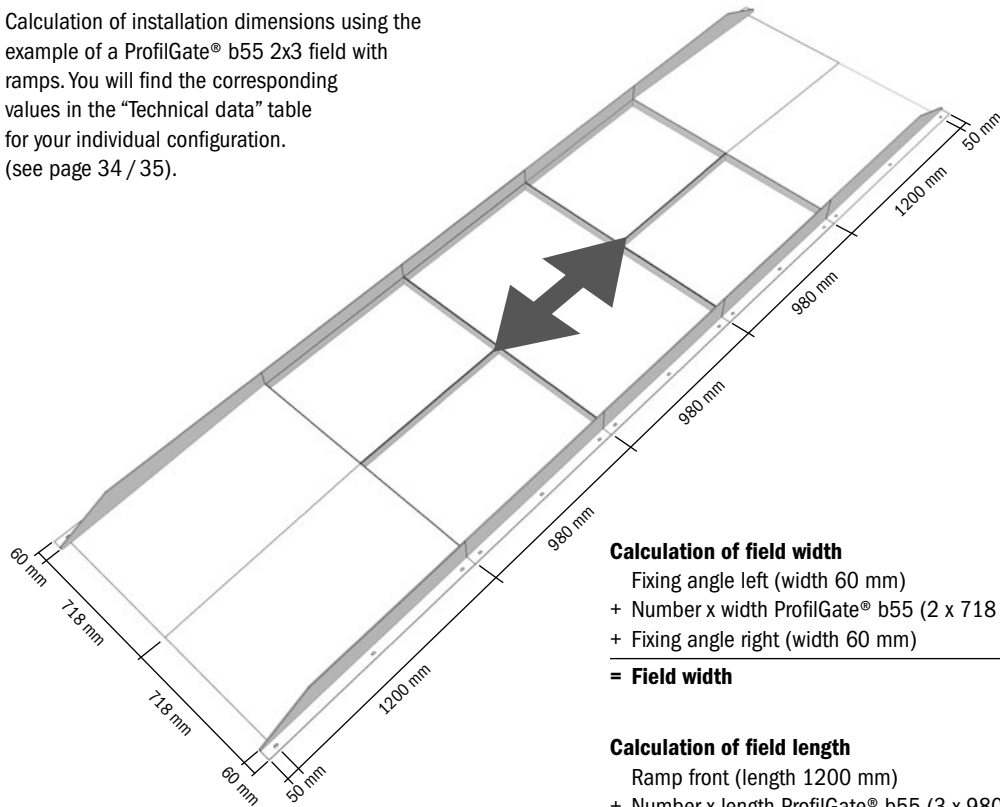

Calculation of field width

Fixing angle left (width 60 mm)	60 mm
+ Number x width ProfilGate® b55 (2 x 718 mm)	1436 mm
+ Fixing angle right (width 60 mm)	60 mm
= Field width	1556 mm

Calculation of field length

Ramp front (length 1200 mm)	1200 mm
+ Number x length ProfilGate® b55 (3 x 980 mm)	2940 mm
+ Ramp rear (length 1200 mm)	1200 mm
= Field length	5340 mm

Fixing angle

- ProfilGate® b65/st65/xs65
- ProfilGate® b55/i55/st55/sti55/xs55

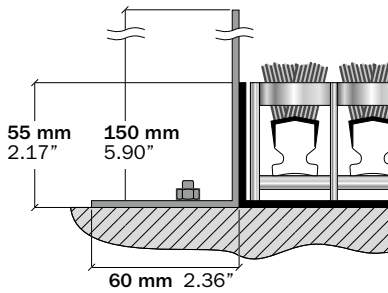

Ramp entrance and exit

- ProfilGate® b55 go/i55 go/st55 go/sti55 go/xs55 go

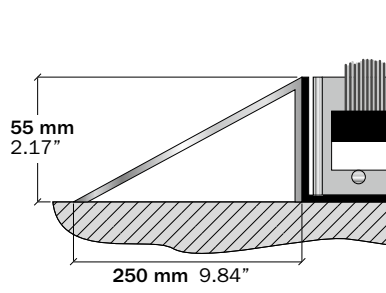

Ramp entrance and exit

- ProfilGate® b65 go/st65 go/xs65 go

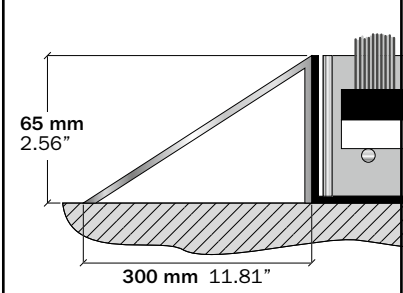

Entrance/exit ramps for above ground installations

- ProfilGate® st55/b55/xs55

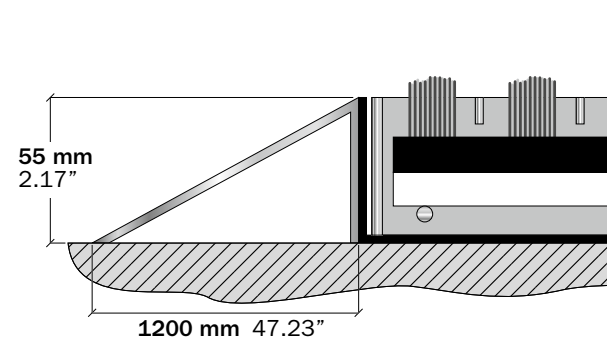

Entrance/exit ramps for above ground installations

- ProfilGate® b65/st65/xs65

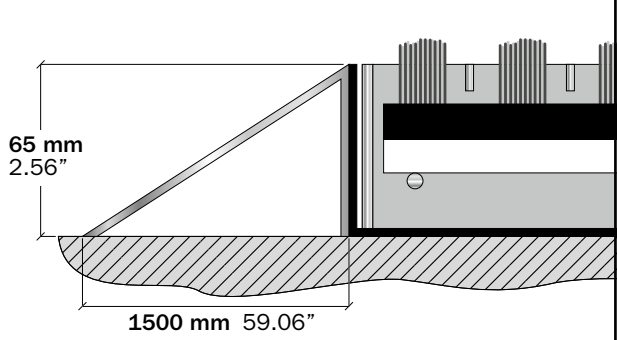

Installation above ground with entrance and exit ramps

- ProfilGate® b55
- ProfilGate® b55 DryZone
- ProfilGate® st55
- ProfilGate® xs55
- ProfilGate® b65
- ProfilGate® b65 DryZone
- ProfilGate® st65
- ProfilGate® xs65



1. Make sure that the area being used has a level and solid foundation.

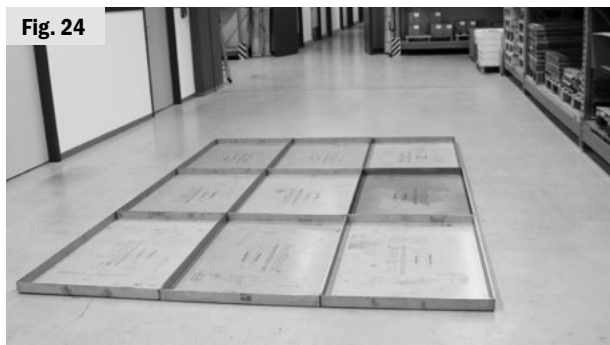

2. Lay out the trays and center them on the lane.



3. Lay out the ramps and center them in the direction of travel.

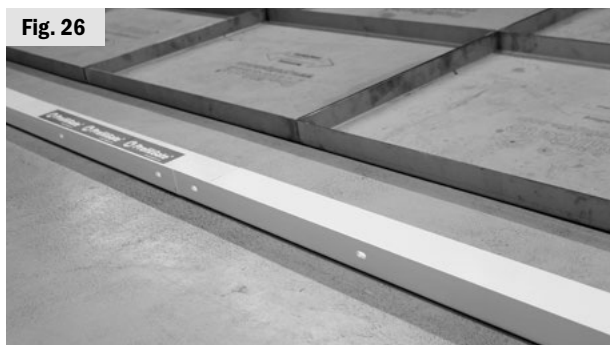

4. Place the fixing corners on the sides of the trays.



5. Prepare the screw fitting of the fixing angle.



6. Screw the side fixing angle into the ground.



7. Also fasten the ramps.



8. Insert the grates with the brush strips in the trays.

Above ground installation with ramps for pedestrians

- ProfilGate® b55 go
- ProfilGate® i55 go
- ProfilGate® st55 go
- ProfilGate® xs55 go
- ProfilGate® b65 go
- ProfilGate® st65 go
- ProfilGate® xs65 go

1. Make sure that the area being used has a level and solid foundation.



2. Lay out the trays at the desired spot. Align the trays flush with each other.

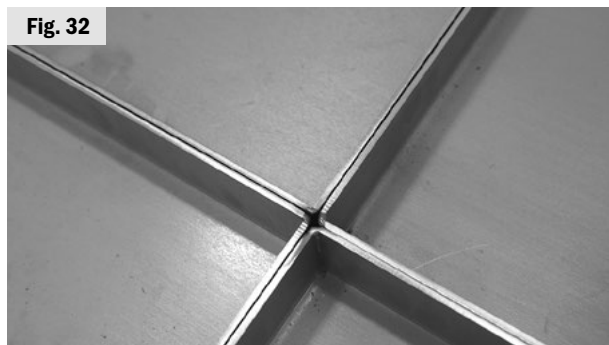

3. Make sure that the height of the adjacent trays does not exceed a tolerance of ± 0.5 mm. Otherwise please check the trays and ground for unevenness.



4. Lay out the ramps at the desired site. Fig. (33)
5. If you do not lay the ramps in a complete arrangement, use instead fixing corners on the tray sides (figure 29) or fasten the trays to the subsurface using screws.



6. Prepare the screw fitting of the ramps/fixing corners. 2 flat head screws (approx. M8) are needed for each fixing corner. The length of the screws and type of dowels must be adjusted to the subsurface.

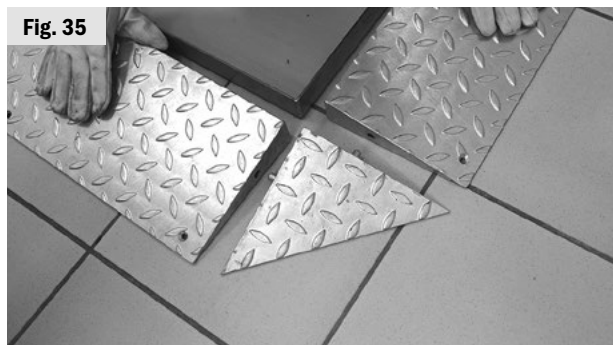

7. Only connect the ramps on the long sides. Slide the corner segments with bolts to the corresponding position before connecting the ramp segments. 3 flat countersunk screws (approx. M6) are needed for each ramp. The length of the screws and type of dowels must be adjusted to the subsurface.



8. Connect the ramps/fixing corners to the subsurface.



9. Insert the grates with brush strips in the trays. Fig. (37)

10. ATTENTION - risk of accident!

Before using/crossing the field, block it off with warning tape/chain barrier, etc. to secure the edges of the cleaning field.

Operation

ProfilGate® function in practice

ProfilGate® is used to remove collections of dirt from tires, wheels, other types of wheels and shoes. The system was designed for use on internal routes. It should be installed on routes (in indoor or covered outdoor areas) that receive high traffic. The removed dirt is caught in the trays underneath and must be disposed of regularly.

A usage other than contact surface cleaning in entrances/passages or personal locks must be explicitly approved by the manufacturer beforehand.

ProfilGate® aqua function in practice

ProfilGate® aqua serves as a wet cleaning and optional disinfectant of tires, wheels, other types of wheels and shoes. The system was designed for use on highly frequented routes indoors. Min. temp. 5°C/41°F, max. temp. 40°C/104°F).

The tray can be filled with cleaning or disinfectant liquid for this purpose. The fill level can be adjusted precisely with the adjustable overflow plugs (see chapter **Service and maintenance** > *Setting the fill level of the ProfilGate® aqua*). The liquid or disinfectant must be replaced regularly. This should occur according to the operational cleaning plan or hygiene concept. A usage other than for contact surface cleaning of tires or shoes must be explicitly approved by the manufacturer beforehand.

ProfilGate® DryZone function in practice

ProfilGate® DryZone is used to remove collections of dirt and moisture from tires, wheels, other types of wheels and shoes. The system was designed for use on indoor routes that are often passed, sometimes also with high loads. Moisture is absorbed by the fleece pads, which have to be replaced as soon as their effect is reduced. Dripping liquid is collected in the tray below it and must be regularly emptied/extracted.

A usage other than for contact surface cleaning of tires or shoes must be explicitly approved by the manufacturer beforehand.

Cleaning quality

The cleaning quality depends directly on the laid field length and the diameter of the wheels to be cleaned. The bigger the wheel diameter, the longer the field must be to ensure a high cleaning quality. A good cleaning quality is ensured if a wheel can completely roll on the system at least three times.

The following table provides information about the expected cleaning effect with different field lengths and different wheel diameters.

Cleaning field		Cleaning quality	
Number of segments	Total length	very good	good
3	≈ 2940 mm	< Ø 230 mm	< Ø 310 mm
4	≈ 3920 mm	< Ø 310 mm	< Ø 415 mm
5	≈ 4900 mm	< Ø 390 mm	< Ø 520 mm
6	≈ 5880 mm	< Ø 465 mm	< Ø 620 mm
10	≈ 9800 mm	< Ø 780 mm	< Ø 1040 mm

Suitability and limits

Even the best system has its limits – and we do not want to make any unrealistic promises. In the following, you will find notes about the suitability and limits of the ProfilGate® system.

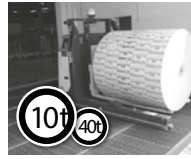

Total weight

The maximum permissible total weight of the vehicles amounts to, depending on the model, up to 40t (see table “Technical data” on page 34-37).



Dust, street dirt and rubber abrasion

The ProfilGate® system reliably picks up this dirt. Even the carryover of moisture and liquids is strongly reduced. When in doubt, please contact us to examine your individual requirements.



Travel direction

The cleaning field is not suitable for passing diagonally, quickly braking or accelerating and turning or rotating in place.



Top speed

The maximum crossing speed is 6 km/h – 4 mph.



Mud and rough dirt

The ProfilGate® is not suitable for very rough dirt caused by mud or other types of stubborn dirt. Other systems would be better for this.

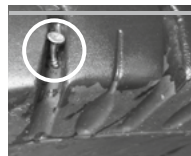

Foreign objects

The ProfilGate® system reliably removes collections of dirt from tires and shoe profiles, however, it cannot pull out any objects that are stuck or deeply embedded.



Usage in clean rooms

ProfilGate® is not suitable for use within clean rooms such as for semi-conductor manufacturing or for the sterile production of food or pharmaceuticals.

The ProfilGate® is frequently used in the preliminary stages, as it can be very helpful there.



Sturdy footwear

The ProfilGate® system may not be passed with high heels, but rather only with sturdy footwear.

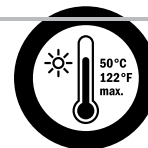

Maximum temperature

ProfilGate® is not suitable for temperatures over 50 °C / 122 °F. Higher temperatures may damage the brush strips.

Service and maintenance

In order to ensure optimal function of ProfilGate®, the system has to be inspected, cleaned and serviced in regularly intervals.

The execution of maintenance work listed in the following may only be performed with the corresponding protective clothing.



Risk of crushing: Do not forget about the risk of crushing caused by the high weight of the grates.



Safety shoes: Always wear safety shoes, because the grates are heavy and could cause injuries if they fall down.



Work gloves: Wear work gloves to prevent cuts caused by sharp foreign objects or splinters.



Goggles: Protect your eyes from any stirred up dust by wearing goggles.



Mouth protection: Wear mouth protection to protect yourself against possible poisonous substances in the dust.

Control

Regularly check the functionality of the system. While doing so, check if any components are damaged or worn and if the cleaning of the trays was executed properly. Make sure that there are no obstacles in the area of the cleaning field that could otherwise impair functionality or safety. Make sure that the brush strips have enough space to allow the dirt to move down to the trays from the sides.

Cleaning

The cleaning intervals of the ProfilGate® field depend on the in-plant operating conditions. Use shorter cleaning intervals with high-volume contamination, particularly in the fall and winter. Extend the intervals correspondingly for lower level contamination. With the ProfilGate® aqua systems, the cleaning also includes the regular replacement of any used cleaning liquid, for example, water with cleaning additives or disinfectant. The composition of which must, of course, correspond to the regulations for hygiene and cleanliness applicable on site.

Maintenance

ProfilGate® systems are considered to be very low-maintenance and reliable. However, there are some components, which will wear after a long period of service and will reduce the cleaning quality – e.g. brush strips, fleece pads, depending on the model.

For brush strips, you can detect excessive wear, for example, through bristles being bent or too soft to actively pick up dirt from a contact surface **Service and Maintenance** > *Inspecting the brush strips*).

With the ProfilGate® DryZone fleece pads, replacement is recommended if the contamination is high. Suitable spare parts can be purchased from your ProfilGate® specialist dealer or manufacturer.

Recommended service intervals

The values specified in the table below are our empirical values. Nevertheless, the respective case of application plays a large role (type of dirt, type of vehicles and properties of the wheels, use for outdoor travels as well as seasonal usage, etc.). An adjustment to the service intervals should occur in accordance with own experience.

ProfilGate® Tray height 55 mm	< 100 Passes per day	< 300 Passes per day	> 300 Passes per day
Control	1x/week	2x/week	daily
Cleaning	every 2 months	1x/month	2x/month
Fleece change only dry zone	1x/week	2-3x/week	every 1-2 days
Brush change all ProfilGate® Models	every 10 years	every 5 years	every 2-5 years

ProfilGate® Tray height 65 mm	< 100 Passes per day	< 300 Passes per day	> 300 Passes per day
Control	1x/week	2x/week	daily
Cleaning	every 3 months	every 2 months	1x/month
Fleece change only dry zone	1x/week	2-3x/week	every 1-2 days
Brush change all ProfilGate® Models	every 10 years	every 5 years	every 2-5 years

Inspection of brush strips

The bristles of the brush strips may not be worn or bent for effective cleaning. Replace as needed.



Fig. 38 No replacement needed yet.

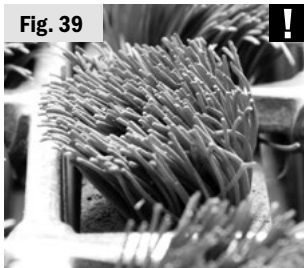

Fig. 39 Brush strip replacement needed soon. Add new brush strips to the next budget.

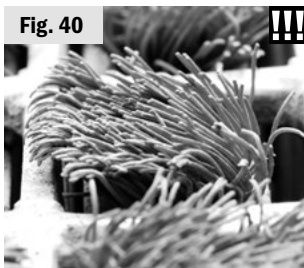

Fig. 40 Urgent brush strip replacement needed. Your cleaning field has a strongly reduced cleaning effect!

Collect/analyze dirt



Fig. 41

1. During the first weeks/months after installation, collect the dirt from the trays and weigh it to determine the cleaning intervals. Upon request, we will provide you with special “dirt collecting bags” for this purpose.



Fig. 42

2. You can determine or adjust the length of the cleaning intervals based on the amount of dirt collected. You can also have the collected dirt analyzed in corresponding laboratories. We would be happy to provide you with the corresponding contacts.

Cleaning interval table

The regular cleaning of ProfilGate® is the basis for the optimal functionality of the system. Determine the cleaning intervals corresponding to the amount of dirt in your system and communicate your guidelines with cleaning companies or your employees. A good possibility for inspection of the cleaning measures is offered by the ProfilGate® cleaning table with control sheets (at a cost, optional accessory), which you can receive from HEUTE Maschinenfabrik on request (figure 43).



Fig. 43

Open grates with ProfilGate® Lifter (1 Person)

- All ProfilGate® models

The ProfilGate® Lifter is an optional accessory and is not included in the scope of delivery.

1. Move the wheels of the ProfilGate® Lifter right in front of the grate to be lifted.



2. Place the wheels so that they do not stand on the grate to be picked up.



3. Lower the ProfilGate® Lifter and let the hooks sink into the grate. Move the ProfilGate® Lifter forward to slide the hooks under the crossbeams of the grate.

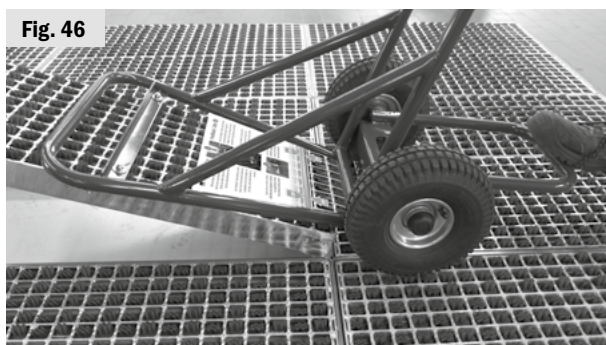

4. Step on the rear bracket of the ProfilGate® Lifters to lift the grate (figure 46).
5. Move the grate away from the cleaning field while lifted and set it down.
6. After the grate has been cleaned, lift it again with the ProfilGate® Lifter. Move to the cleaning field and place the wheels from the lifter so that they are in front of the tray to be equipped. Lower the grate into the tub and pull the ProfilGate® Lifter back a little to loosen the hooks from the grate.

Open grates with short lifting hooks (2 people)

The short ProfilGate® lifting hooks are included in the scope of delivery.

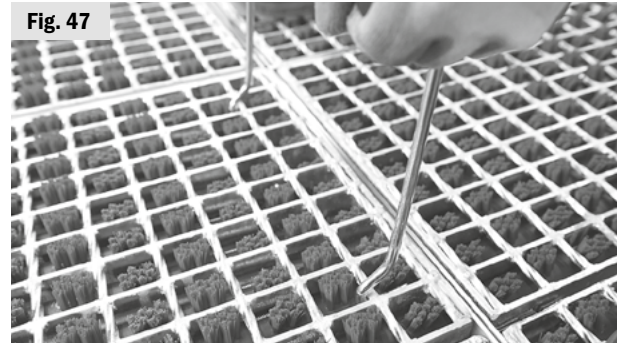

1. Hook in two lifting hooks per person up to the stop in the grate. Make sure that the spacing between the hooks is about a shoulder-width.

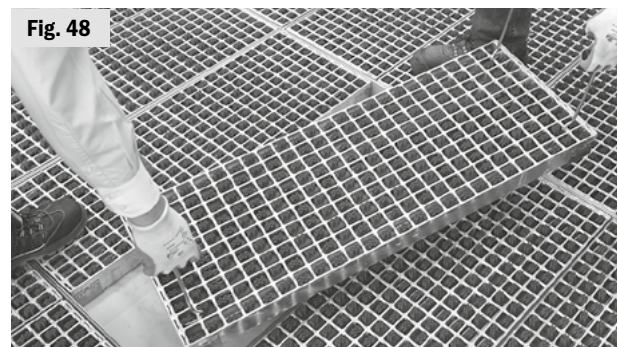

2. Lift the grate from the tray together with the second person simultaneously and set it down to the side (figure 48).
3. When setting down the grate, make sure that there are not any heavy objects on the brush strips.
4. When reinserting the grate, make sure that it is level on the tray floor.



5. Store the lifting hooks in the designated wall bracket (at a cost, optional accessory).

Open grates with long lifting hooks (2 people)

The long ProfilGate® VA lifting hooks are an optional accessory and is not included in the scope of delivery.

Fig. 50

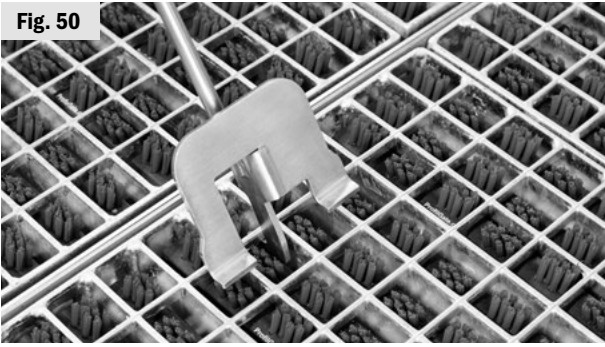

1. Hook in one lifting hook per person up to the stop, each in one center grate.

Fig. 51

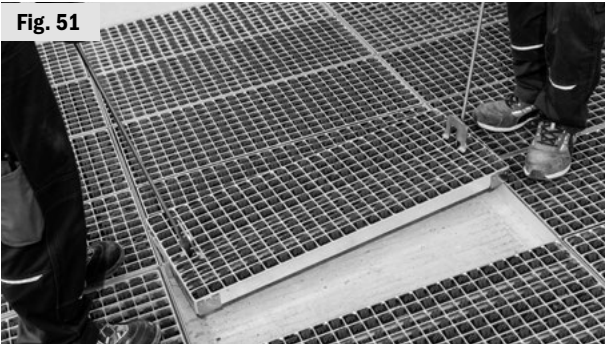

2. Lift the grate from the tray together with the other person simultaneously and set it down to the side (figure 51).
3. When setting down the grate, make sure that there are not any heavy objects on the brush strips.
4. When reinserting the grate, make sure that it is level on the tray floor.

Fig. 52

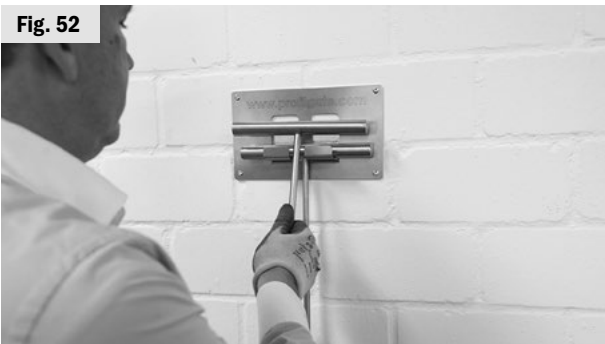

5. Store the lifting hooks in the designated wall bracket (at a cost, optional accessory).

Complete cleaning after removing the grate

- All ProfilGate® models

First open one or several segments from the system (see Chapter **Service and Maintenance** > *Open grate*). Use an industrial vacuum (figure 53) or a dustpan (figure 54) to remove the collected dirt after cleaning.

Fig. 53

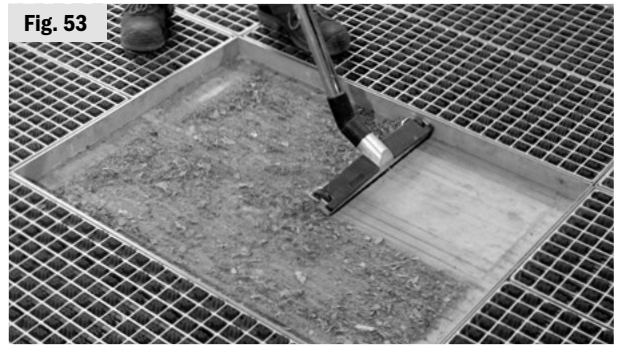

Fig. 54



Complete cleaning wet after grate removal

- All ProfilGate® models

Fig. 55



1. Lift the grates completely from the tray / trays (see Chapter **Service and Maintenance** > *Open grates*) and then rinse them. Remove the liquid, for example, with a suitable wet vacuum.

Complete cleaning ProfilGate® aqua after grate removal

All ProfilGate® aqua models

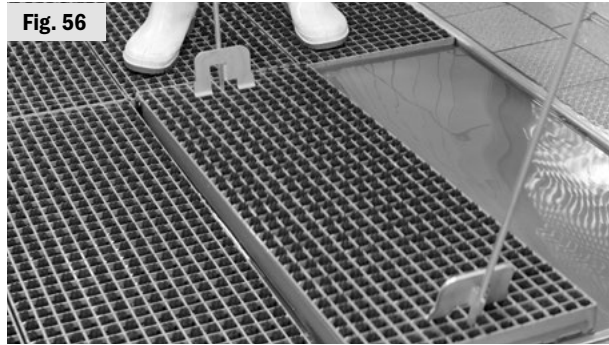

1. Lift the grate completely out of the tray with two people.



2. Remove the overflow plug to allow liquid to drain.



3. Use a squeegee to let all liquid drain.



4. Rinse the entire tray with clean water.

Setting the fill level of ProfilGate® aqua

All ProfilGate® aqua models

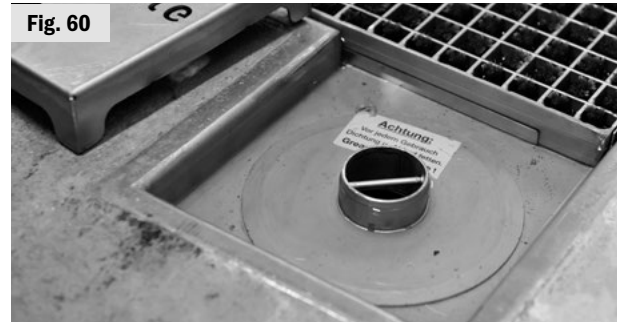

1. The fill level in the tray determines the amount of liquid that will be transported through the bristles to the wheels and tires. A default fill level is preset, however, it can be adjusted individually and precisely. This is done with the aid of the adjustable overflow plug.

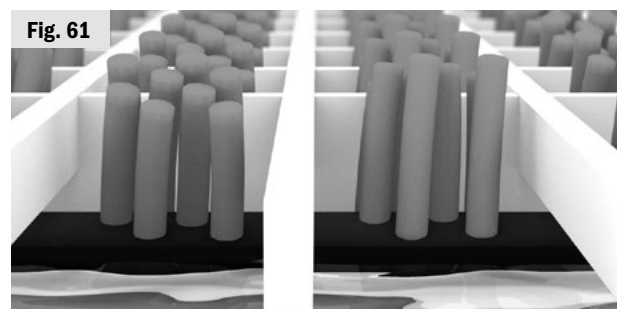

2. With a low fill level, the “bristle feet” in the middle of the brush strip (highest point) will only enter the liquid during travel. This provides for wet contact surfaces, good cleaning and low liquid carryover.

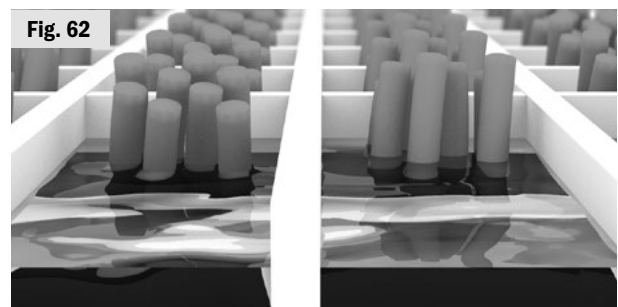

3. With a high fill level, the “bristle feet” in the middle of the brush strip (highest point) are in the water even without a load. This provides for wetter contact surfaces, more intense cleaning, but also more liquid carryover.



4. In order to change the fill level, remove the overflow plug from the drain and turn the pipe sticking out against the seal regulator. Unscrew the pipe counter-clockwise to increase the fill level. Screw in the pipe clockwise to lower the fill level. Test a new setting and make sure that the tray does not overflow.

Brush replacement with quick-release axle

(at a cost, optional accessories)

All ProfilGate® models



- 1.** Place the grate with the brush side facing down in the frame (additional article, at a cost).



- 2.** Push down the brush strips with the change aid (at a cost, accessory).



- 3.** Remove the quick-release axle completely from the grate using the side cavity (if necessary, using pliers).



- 4.** Push down the brush strips on the other side of the grate with the change aid as well.



- 5.** Remove the quick-release axle completely from the grate using the side cavity.

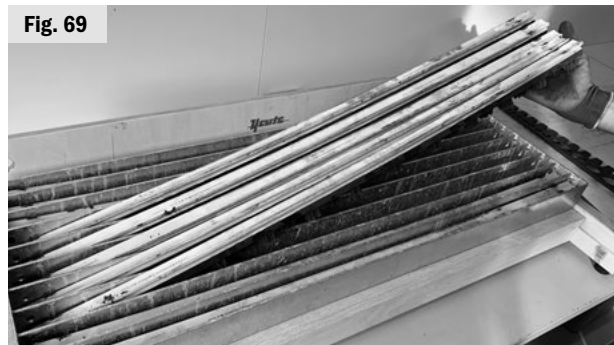

- 6.** Remove the worn brush strips.
7. Insert the new brush strips in the grate.



- 8.** Push down on the side of the brush strip with the change aid again.

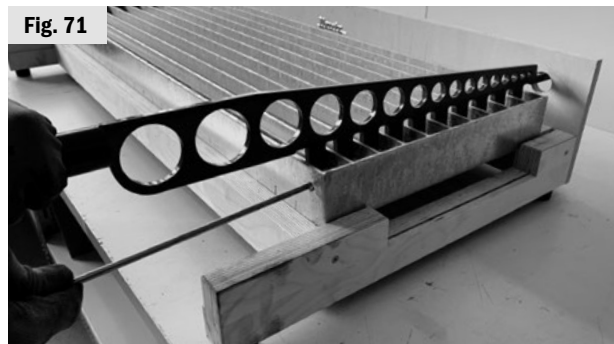

- 9.** Guide the quick-release axles through the side cavity into the grate. Slide the quick-release axle completely until the stop.
10. Repeat step 8 (figure 70) and step 9 (figure 71) on the other side of the grate.

Trouble shooting by qualified personnel

? Bristles get torn out

! Wheels were turned or strongly accelerated or braked on the cleaning field.

✓ Avoid turning and strong acceleration/braking on the cleaning field as much as possible.
Replace any damaged brush strips

or

! Pallets were pulled or slid on the cleaning field

✓ Lift up fork lift and pallet when crossing

? Brush strips no longer lower

! Too much dirt has collected under the brush strips or an object has gotten stuck in the side, for example, a screw

✓ Lift grate and clean tray/remove
Stuck objects

? Brush strips are hanging or no longer lower

✓ Brush strips have serious wear and must be replaced (all models) or an object has gotten stuck in the side, for example, a screw.

? Dust is stirred up when driving over the cleaning field.

! Tray is filled with too much dirt.

✓ Lift grate and clean tray, shorten cleaning interval

? Bristles are bent

! The bristles are strongly worn (see example image)



✓ Replace brush strips

? Grates move when passing in trays

! Too much dirt under the grates

✓ Lift grate and clean tray,
Reduce speed

? Liquid runs over the edge of the tray (only ProfilGate® aqua)

! Drain clogged or fill level too high

✓ Clean drain or drain/extract excess liquid

✓ Readjust overflow plugs (height-adjustable)

? Liquid sprays out while passing (only ProfilGate® aqua)

! Passing speed too high

✓ Drive slower

or

! Fill level too high

✓ Drain/extract excess liquid

✓ Readjust overflow plugs (height-adjustable)

? Wheels are not as wet as desired (only ProfilGate® aqua)

! Fill level in tray too low

✓ Refill cleaning liquid

or

✓ Check correct position of overflow

✓ Readjust overflow plugs (height-adjustable)

? Fleece comes loose from grate/tray (only ProfilGate® DryZone)

! Clamping roller has come undone

✓ Realign fleece and fix with clamping roller

? Fleece has torn (only ProfilGate® DryZone)

! Wear through frequent passing

or

! Damage through sharp objects

✓ Replace fleece

D

EN

F

IT

ES

TR

Dieses Handbuch enthält Beschreibungen unserer Produkte, allerdings keine Garantien für bestimmte Eigenschaften oder Einsatzerfolge. Maßgebend ist, soweit nicht anders vereinbart, der technische Stand zum Zeitpunkt der gemeinsamen Auslieferung von Produkt und Bedienungsanleitung durch die HEUTE Maschinenfabrik GmbH & Co. KG. Konstruktion und Technik unterliegen ständiger Weiterentwicklung und Verbesserung. Technische Änderungen bleiben vorbehalten. Dieses Handbuch ist urheberrechtlich geschützt. Alle Rechte bleiben vorbehalten. Das Kopieren, Vervielfältigen, Übersetzen oder Umsetzen in irgendein elektronisches Medium oder maschinell lesbare Form im Ganzen oder in Teilen ist nur mit ausdrücklicher schriftlicher Genehmigung der HEUTE Maschinenfabrik GmbH & Co. KG gestattet.

This manual comprises the description of our products, however it does not guarantee certain properties or success in use. Provided nothing to the contrary has been agreed upon, the technical condition at the point of delivery of the product together with the operating manual by HEUTE Maschinenfabrik GmbH & Co. KG is decisive. Design and engineering is subject to continuous further development and improvement. Subject to technical modifications. This manual is protected by copyright. All rights reserved. Copying, reproducing, translating or converting into any electronic medium or machine readable form in whole or in part shall be permitted only with the explicit written approval of HEUTE Maschinenfabrik GmbH & Co. KG.

Ce manuel comprend la description de nos produits, mais pas des garanties pour certaines caractéristiques ou des résultats d'utilisation. Sauf autre accord, le niveau de la technique au moment de la livraison tant du produit comme du manuel d'instructions par HEUTE Maschinenfabrik GmbH & Co. KG est déterminant. La construction et la technique font l'objet d'une évolution et d'une amélioration constante. Nous nous réservons le droit d'effectuer des modifications techniques. Ce manuel est protégé par des droits d'auteur. Tous droits restent réservés. Le copier, photocopier, traduire ou recomposer dans quelconque moyen électronique ou forme lisible mécaniquement dans son tout ou partie, nécessite une autorisation explicite et écrite de la part de HEUTE Maschinenfabrik GmbH & Co. KG.

Questa guida contiene la descrizione dei nostri prodotti ma non include la garanzia per determinate caratteristiche o risultati di utilizzo. Se non accordato diversamente, fa riferimento lo stato della tecnica nel momento della consegna del prodotto e del manuale d'utilizzo da parte dell'impresa HEUTE Maschinenfabrik GmbH & Co. KG. La costruzione e la tecnica sono continuamente soggette ad evoluzione e miglioramento. Eventuali modifiche tecniche sono riservate. Questa guida è protetta da diritti d'autore. Tutti i diritti sono riservati. La copia, la riproduzione, la traduzione o il trasferimento su qualsiasi dispositivo in formato elettronico o in forma leggibile a macchina, di parte o dell'intero testo, è solamente ammesso tramite l'esplicito consenso scritto da parte dell'impresa HEUTE Maschinenfabrik GmbH & Co. KG.

Este manual comprende la descripción de nuestros productos, pero ninguna garantía para ciertas características o resultados de utilización. Salvo otro acuerdo, el estado de la tecnología al momento de la entrega tanto del producto como del manual de instrucciones por HEUTE Maschinenfabrik GmbH & Co. KG es determinante. La construcción y la técnica son el objeto de una evolución y de una mejora constante. Nos reservamos el derecho de efectuar modificaciones técnicas. Este manual está protegido por unos derechos de autor. Todos los derechos están preservados. Copiar, fotocopiar, traducir o recomponerlo en cualquier medio o forma legible mecánicamente en su totalidad o parte, requiere una autorización explícita y escrita de parte de HEUTE Maschinenfabrik GmbH & Co. KG.

Bu el kitabı ürünlerimizin açıklamalarını içerir, ancak, belirli özellikleri ya da kullanım sonuçlarının garantisizdir. Belirleyici olan, aksi kararlaştırılmadıkça, HEUTE Maschinenfabrik GmbH & Co. KG'nin sevki ettiği ürün ve kullanım talimatlarının güncel teknik durumudur. Sürekli geliştirme ve iyileştirme tasarım ve teknoloji konusudur. Teknik değişiklikler üreticinin hakkıdır. Kullanma kılavuzu telif haklarına sahiptir ve tüm hakları saklıdır. Herhangi bir elektronik ortamda tamamen veya kısmen makinede okunabilir formda kopyalanması, çoğaltılması, çeviri veya dönüşümü, HEUTE Maschinenfabrik GmbH & Co. KG'nin yazılı izni ile verilir.



Höhscheider Weg 37 · 42699 Solingen · Germany
Tel.: +49 212-380 310 · Fax: +49 212-380 31 39
info@heute-gmbh.de · info@profilgate.com
www.heute-gmbh.de · www.profilgate.com

